

# HeroEE **16**

(HeroEE 16 User Manual)

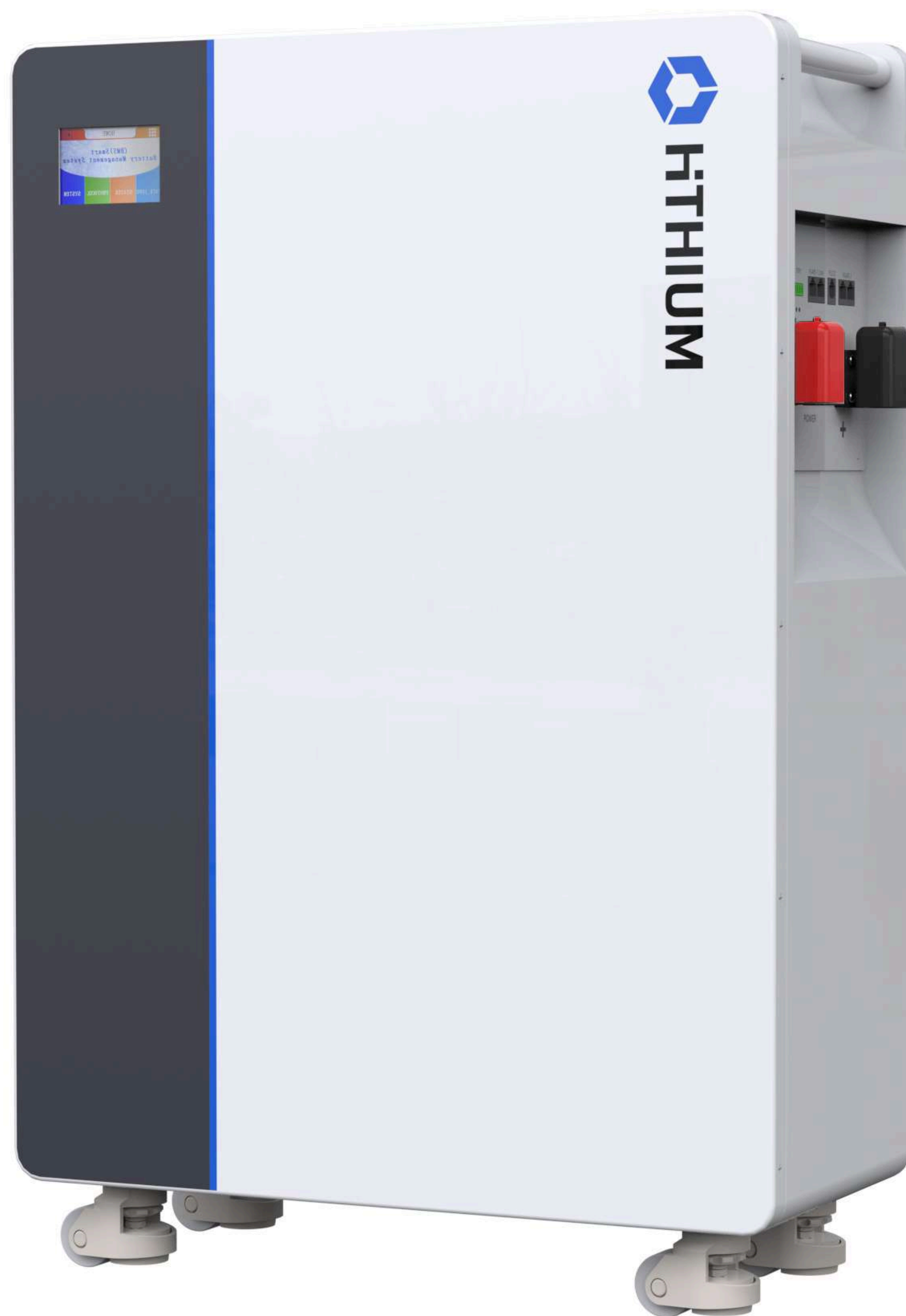

(V3.0.2)

## Contact Us:

<https://www.hero-ee.com>

## Respected user:

Thank you for using Shenzhen Hithium Hero Energy Equity Energy Storage Battery. In order to facilitate the correct operation of this battery, please read this manual carefully before use. Please be sure to read Chapter 1 "Safety Notes " carefully.

## 1. Safety notes

### **Warning!**

- Before operating the equipment in the system, please make sure that the equipment is powered off to avoid the risk of electric shock!
- During the operation of the equipment, all safety precautions in this manual and the safety labels on the equipment must be strictly followed!
- The company is not responsible for any losses caused by violations of general safety operating requirements or safety standards for equipment design, production, and use!
- Without official authorization, do not disassemble, modify, or repair the battery, otherwise there may be a risk of electric shock or equipment damage, and the resulting losses are not within the scope of our company's responsibility!

### **Attention!**

- It is very important and necessary to carefully read the user manual (attachment) before installing or using the battery. The safety precautions mentioned in this manual do not represent all the safety precautions that should be taken, but only supplement all safety precautions.

## 1.1 General Precautions

1. When installing, operating, and maintaining equipment, comply with local safety laws and regulations.
2. When installing, operating, or maintaining equipment, do not wear any conductive items such as watches, bracelets, bracelets, rings, etc.

3. If the battery is stored for too long, it needs to be charged and discharged at least every three months, and the battery level should not be less than 70%.
4. After the battery is fully discharged, it needs to be charged within 12 hours.
5. Before maintenance, it is necessary to turn off the power of the battery and equipment.
6. Do not use cleaning solvents to clean the battery.
7. Do not expose the battery to flammable or irritating chemicals or vapors.
8. Do not connect the battery directly to the solar photovoltaic wire.
9. Do not insert any foreign objects into any part of the battery.
10. The battery is for building in use in final system and its positive and negative terminals are non - accessible.

### 1.2 Before installation

1. After unpacking, please check the product and packaging list first. If the product is damaged or missing parts, please contact the local retailer.
2. Before installation, please cut off the power grid and ensure that the battery is turned off.
3. The wiring must be correct, do not reverse the positive and negative cables, and ensure that there is no short circuit with external equipment.
4. Please ensure that the electrical parameters of the battery system are compatible with the relevant equipment.
5. Please place the battery away from water and fire.

### 1.3 When using

1. If the battery system needs to be moved or repaired, the power must be cut off, and the battery will stop working completely.
2. Prohibit connecting batteries to different types of batteries.
3. Do not connect batteries to faulty or incompatible devices.
4. In the event of a fire, only dry powder fire extinguishers can be used, and liquid fire extinguishers are prohibited.
5. Unauthorized disassembly of batteries is prohibited.
6. Prohibit the use of cables that do not meet the specifications. Pay attention to avoid cables that are too thin, which can cause serious heating and fires!
7. Prohibit direct connection of batteries and AC power sources.
8. The internal shielding system of the battery is designed for 48VDC, and series connection is prohibited.

## 2. Product introduction

This series battery pack is a new type of energy storage product that can be used to provide reliable power for various devices and systems. It is especially suitable for applications with high power, limited installation space, limited load-bearing capacity and long service life. The intelligent BMS battery management system built into the battery can manage and monitor battery voltage, current, temperature and other information. In addition, the battery pack can balance the charge and discharge of the cells to extend cycle life. Multiple HeroEE 16 can be connected in parallel to expand capacity and power, and parallel expansion of capacity can meet the requirement of longer time usage.

## 3. Product features

As a new energy storage product, This series battery pack has the following product characteristics:

- Environmentally friendly and pollution-free: the materials used in the entire battery module are non-toxic and pollution-free;
- Long safety life: The battery module is composed of lithium iron phosphate (LiFePO<sub>4</sub>) batteries, which has good safety performance and long service life.
- Protection function: The battery management system can protect the battery module from over-discharge, over-charge, over-current and high/low temperature;
- Balancing function: The battery management system comes with passive balancing, which can balance each single string of cells in the battery module;
- Capacity expansion: Flexible configuration, multiple battery modules can be connected in parallel to expand capacity, suitable for different backup time requirements;
- Low power consumption: The battery has an automatic sleep function. When not connected to any powered device, it can enter a low power consumption state to reduce self-loss;
- No memory: no memory effect, excellent shallow charge and discharge performance;
- Wide temperature range: operating temperature range -20°C ~40°C, charging 0°C ~40°C, discharging -20 °C ~40°C, with good discharge performance and cycle life;
- Portability: small size, light weight, standard embedded battery modules are more convenient to install and maintain.

## 4. Appearance

### 4.1 Appearance

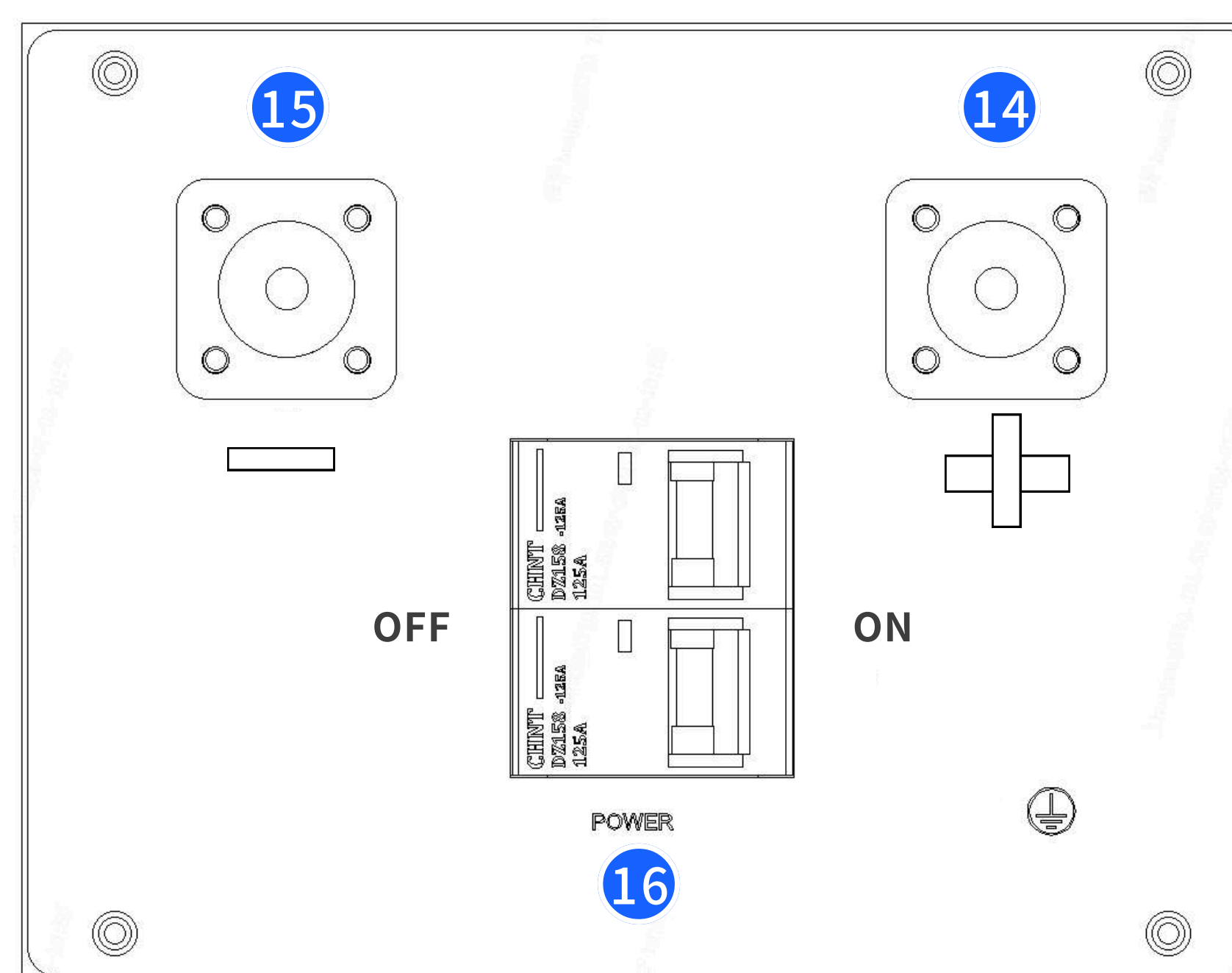
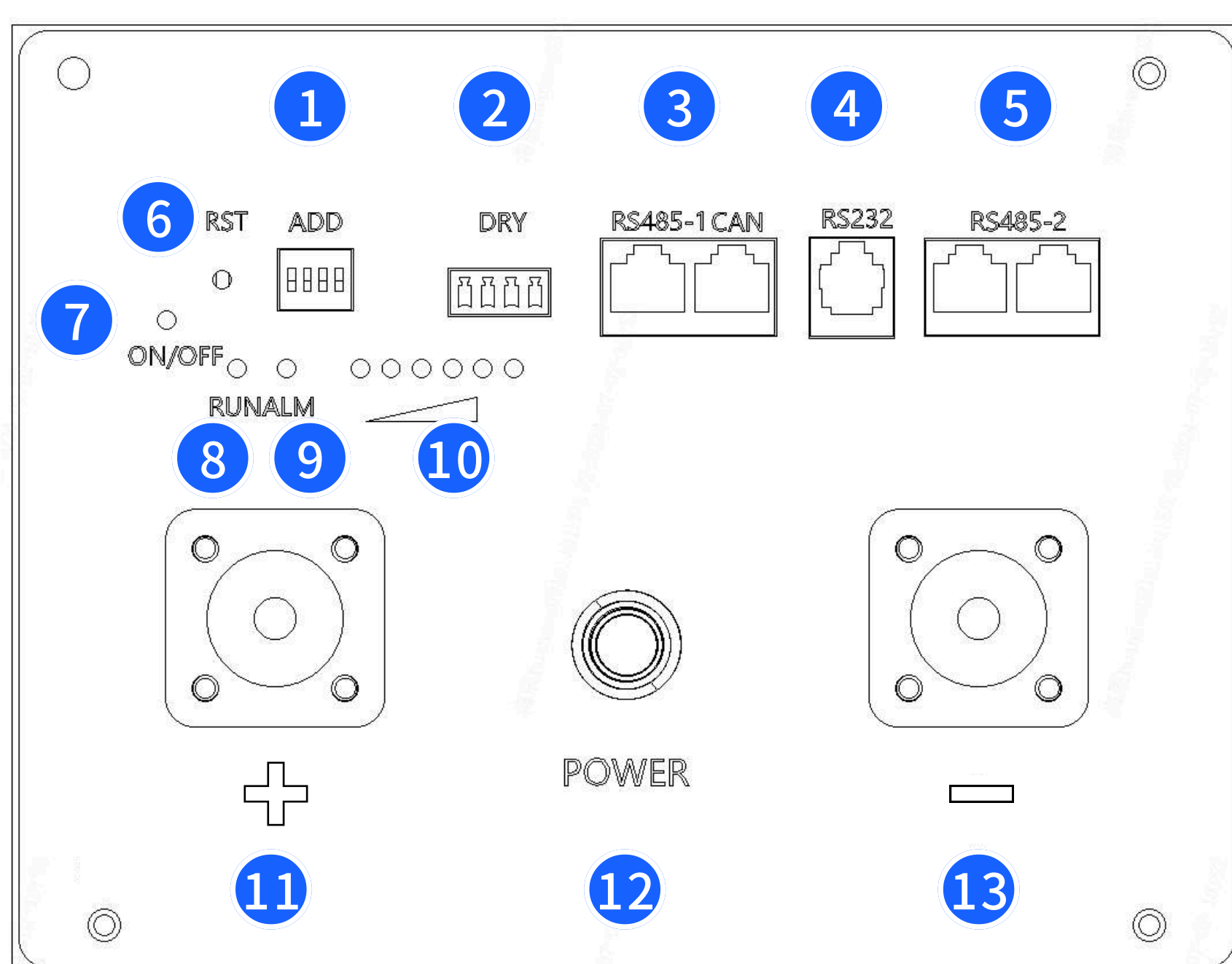
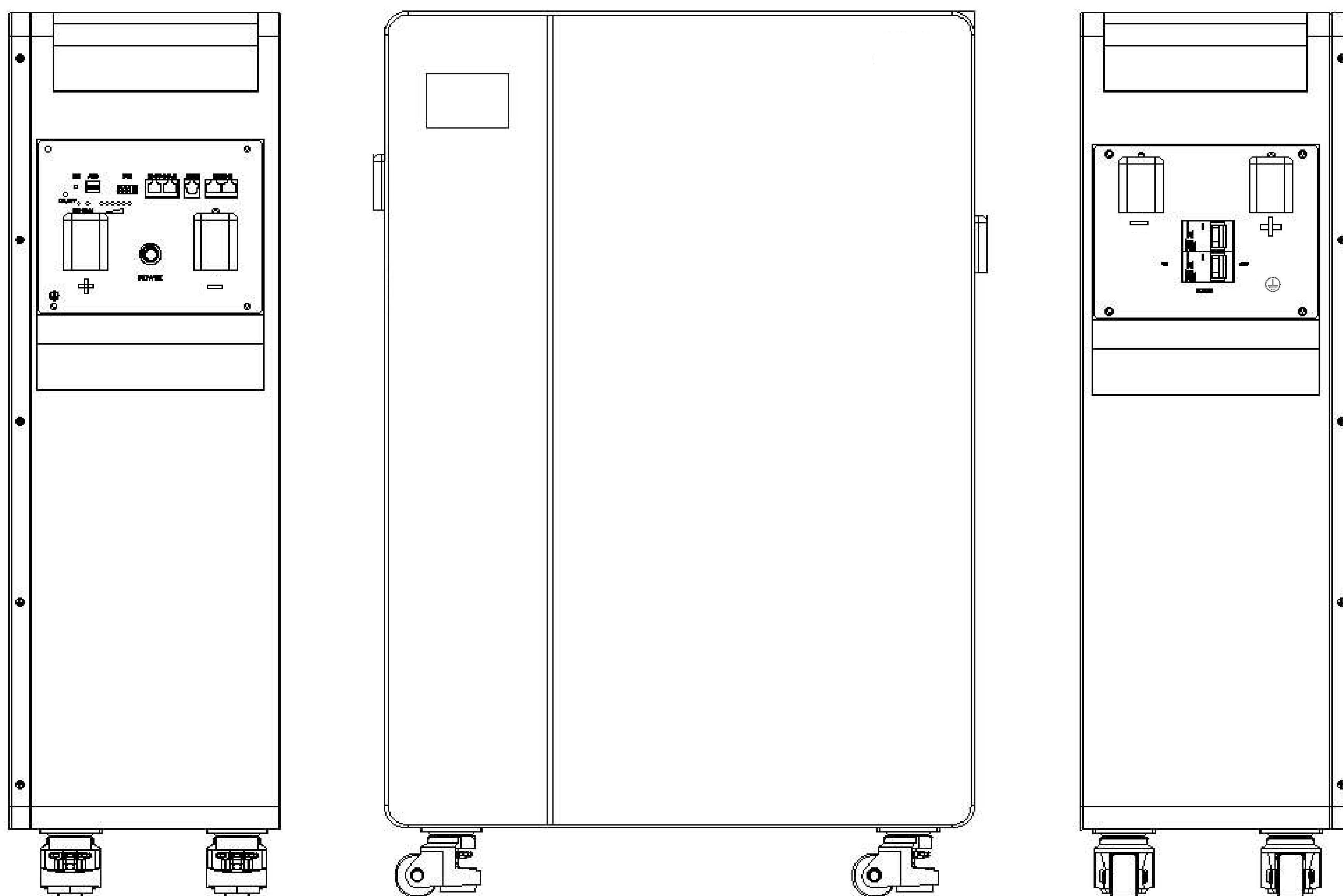

- |  |                                   |
|--|-----------------------------------|
| 1. DIP switch address ADD                          | 9. Alarm indicator light          |
| 2. Dry contact                                     | 10. Battery level indicator light |
| 3. BMS communication interface RS485/CAN           | 11. Battery positive terminal     |
| 4. Host computer communication interface RS232     | 12. Power on/off button           |
| 5. Battery cascading communication interface RS485 | 13. Battery negative terminal     |
| 6. Reset button                                    | 14. Battery positive terminal     |
| 7. Power switch indicator light                    | 15. Battery negative terminal     |
| 8. Operation indicator light                       | 16. POWER                         |

## 4.2 Size

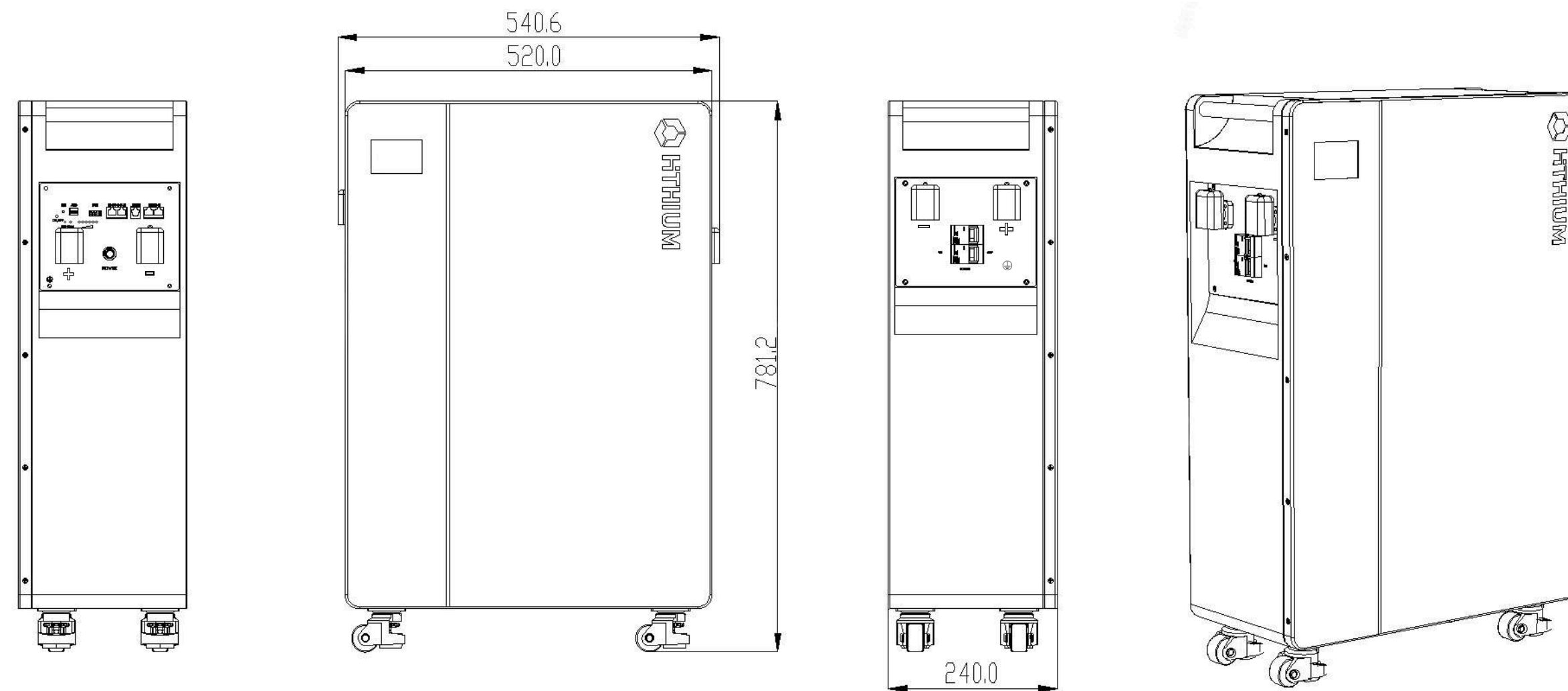

Size: L×W×H(mm): 540.6\*240\*781.2(mm)

## 4.3 Technical parameters

Model No.	HERO EE16
Battery Chemistry	Lithium-iron phosphate (LiFePO4)
Battery Capacity [kWh]	16kWh (with built-in Hithium 314 Ah battery cell -16S1P)
Battery Cell Lifespan	11000 cycles@(25°C , 100%DOD , 0.5P , @70%SOH)
Product Lifespan	Cycle life: >8000 cycles@ 20-25°C@100A @90%DoD
Rated Voltage [VDC]	51.2 [VDC]
Discharge Voltage Range [VDC]	43.2- 56.8 [VDC]
Charge Voltage Range [VDC]	43.2- 56.8 [VDC]
Recommend Charge / Discharge Current [A]	100 A
Max Charge / Discharge Current[A]	200 A @ 1h
DoD [%]	100%
Charge Mode	CC - CV
Charge / Discharge Port	M8 Bolt
Build-in Communication Ports	CAN/RS485/RS232 Wifi/Bluetooth(optional)
Build-in Screen	Yes, LCD Touchscreen
Scalable (Max units in parallel)	Up to 16 batteries, 256 kWh
Compatible Inverter Brands	Victron Energy/Deye/Voltronic/SMA/ GoodWe/ Growatt/TBB/MUST/ ....
IP Rating	IP30
Recommend Operating Temperature [°C]	Charging: 0°C~40°C/Discharging: -20°C~40°C
Recommend Storage Temperature [°C]	Storage: -20°C~60°C
Humidity [%]	10% - 90% RH
Operating Altitude	≤2000m
Cooling	Natural Cooling
Protection	Over-temperature Protection, Under-temperature protection,Over-charge Protection, Over-current Protection, Short-circuit Protection, Under-voltage Protection,Reverse connection Protection, Fault Protection

Dimension [mm]	L540.6*W240*H781.2mm (without Wooden box) L600*W320*H1120mm (with Wooden box)
Weight [kg]	Approx. 110kg (Net Weight) / 135kg(Gross Weight with Wooden box)
Wheels	Four
Certification	UN38.3/MSDS/IEC62619
Note : Shenzhen Hithium Hero Energy Equity reserves the right to amend this datasheet due to design changes. Please kindly refer the latest version of the datasheet.	

## 5.list of attachments

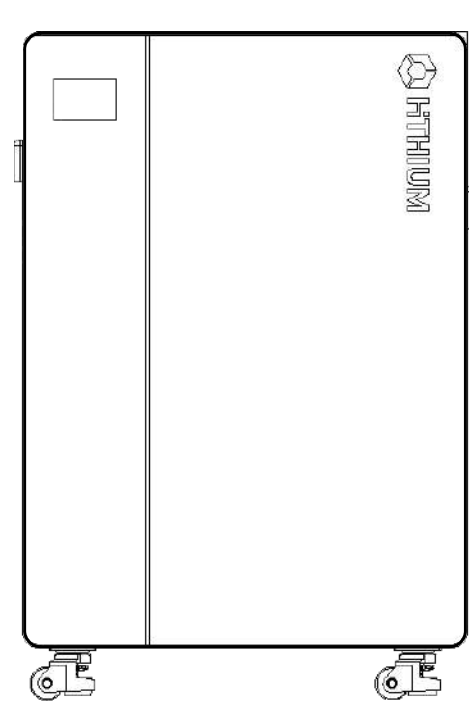

Battery x 1



2-meter 2AWG load wire x 2



communication wire x 1

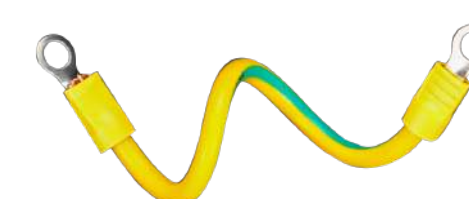

grounding wire x 1

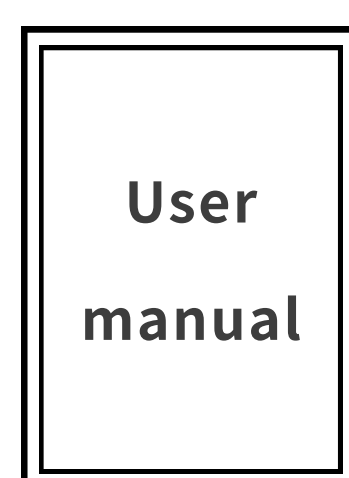

instruction manual  
warranty card x 1



load wire screw x 5



grounding wire screw x 2



RJ45 connector x 1

## 6.Installation instructions

### 6.1 Tools

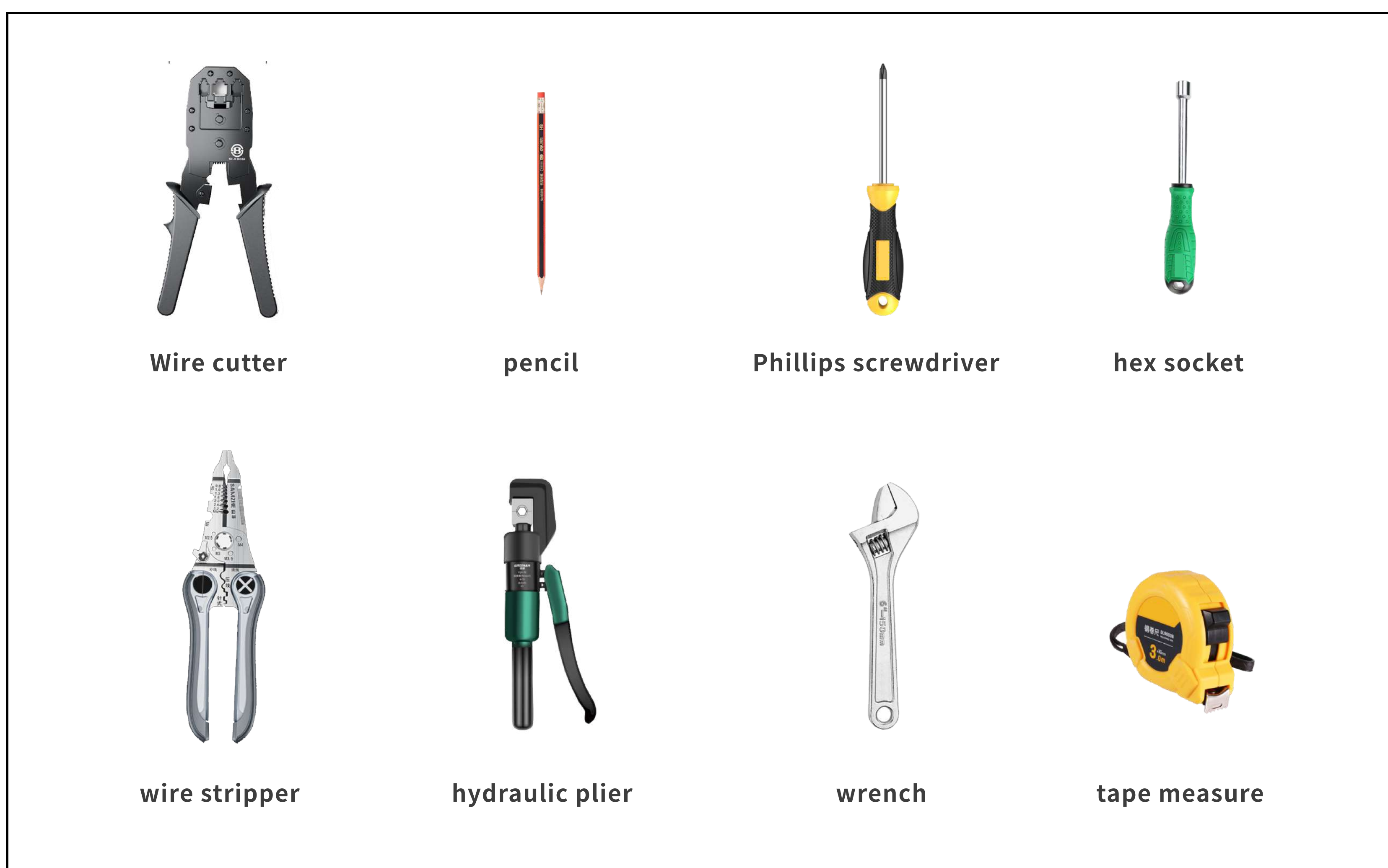

## 6.2 Suggestions for installation placement location

1. **Safety First:** Choose a stable, dry, and well-ventilated location, avoiding placing the battery pack near flammable materials or areas prone to flooding.
2. **Accessibility:** The battery pack should be installed in a location that is easily accessible for daily operation and maintenance, without obstructing other equipment or activities.
3. **Environmental Considerations:** Consider the impact of ambient temperatures on battery performance. Avoid installing the battery pack in environments with extreme heat or cold.
4. **Space Requirements:** Ensure there is adequate space around the battery pack for heat dissipation and to prevent overheating. It is recommended to leave at least 20 cm of space around the battery pack.
5. **Protection Measures:** If the battery pack is installed outdoors, consider using appropriate protective measures, such as a sunshade or waterproof casing, to protect the battery pack from harsh weather conditions.
6. **Load-bearing Capacity:** Ensure the installation surface can support the weight of the battery pack, especially for heavier 16-kWh battery packs.
7. **Electrical Connections:** Consider the connection paths between the battery pack and power sources, loads, and other electrical equipment, ensuring that wiring is reasonable, safe, and avoids excessive bending or stretching of cables.
8. **Compliance with Regulations:** Comply with local electrical installation and safety regulations to ensure the installation meets all applicable standards and requirements.
9. **Maintenance and Inspection:** Choose a location that facilitates regular inspection and maintenance to promptly identify and resolve potential issues.

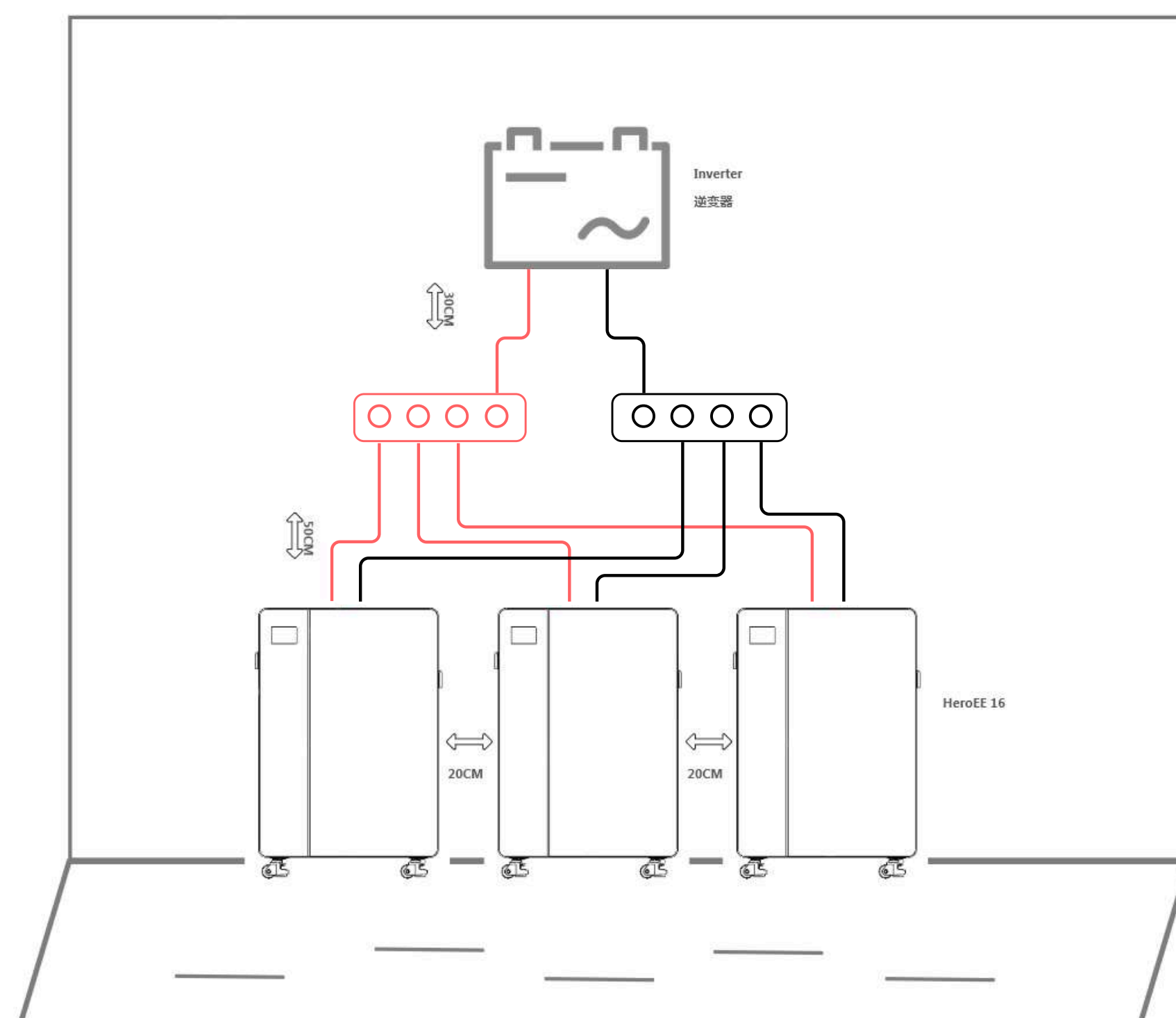

## Mounting location

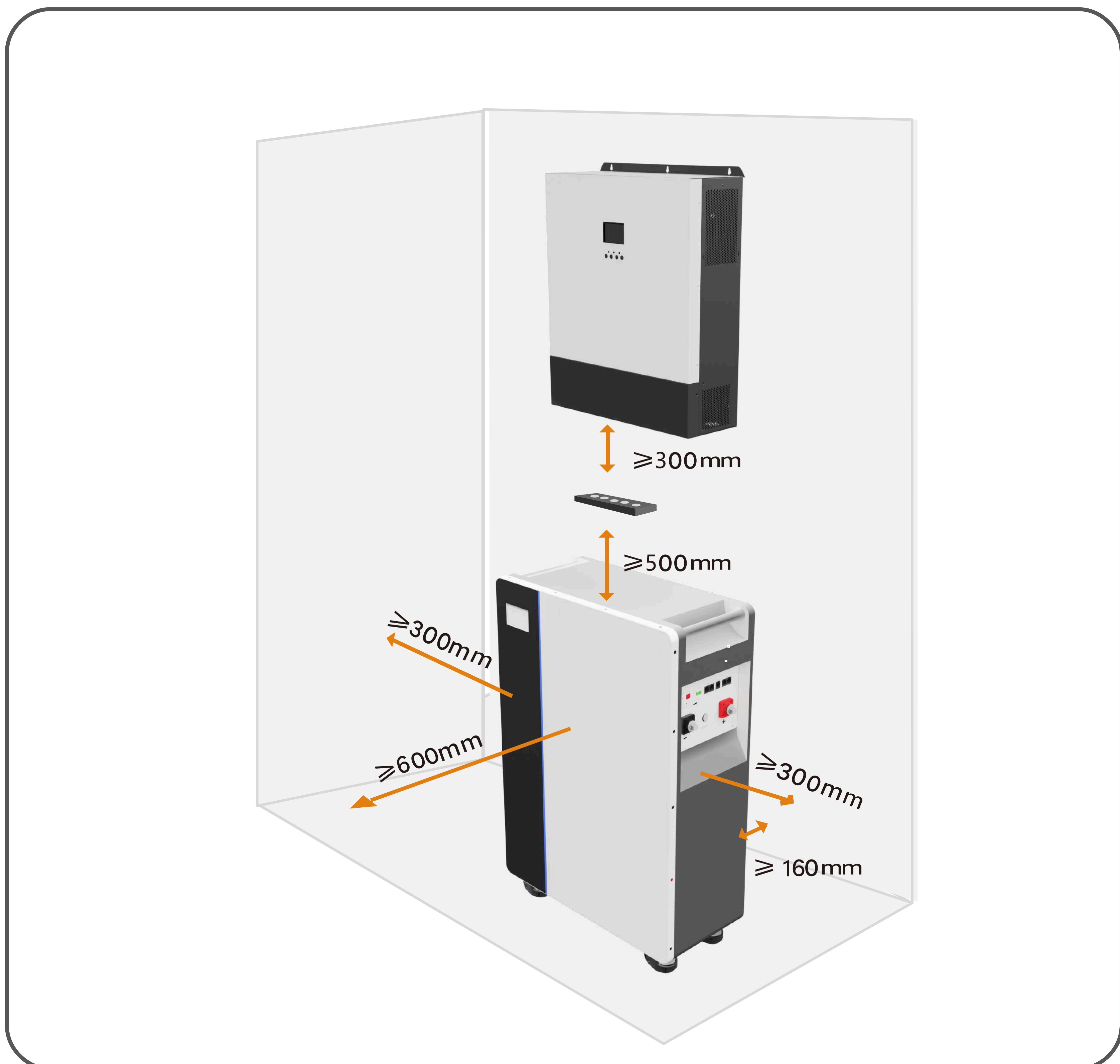
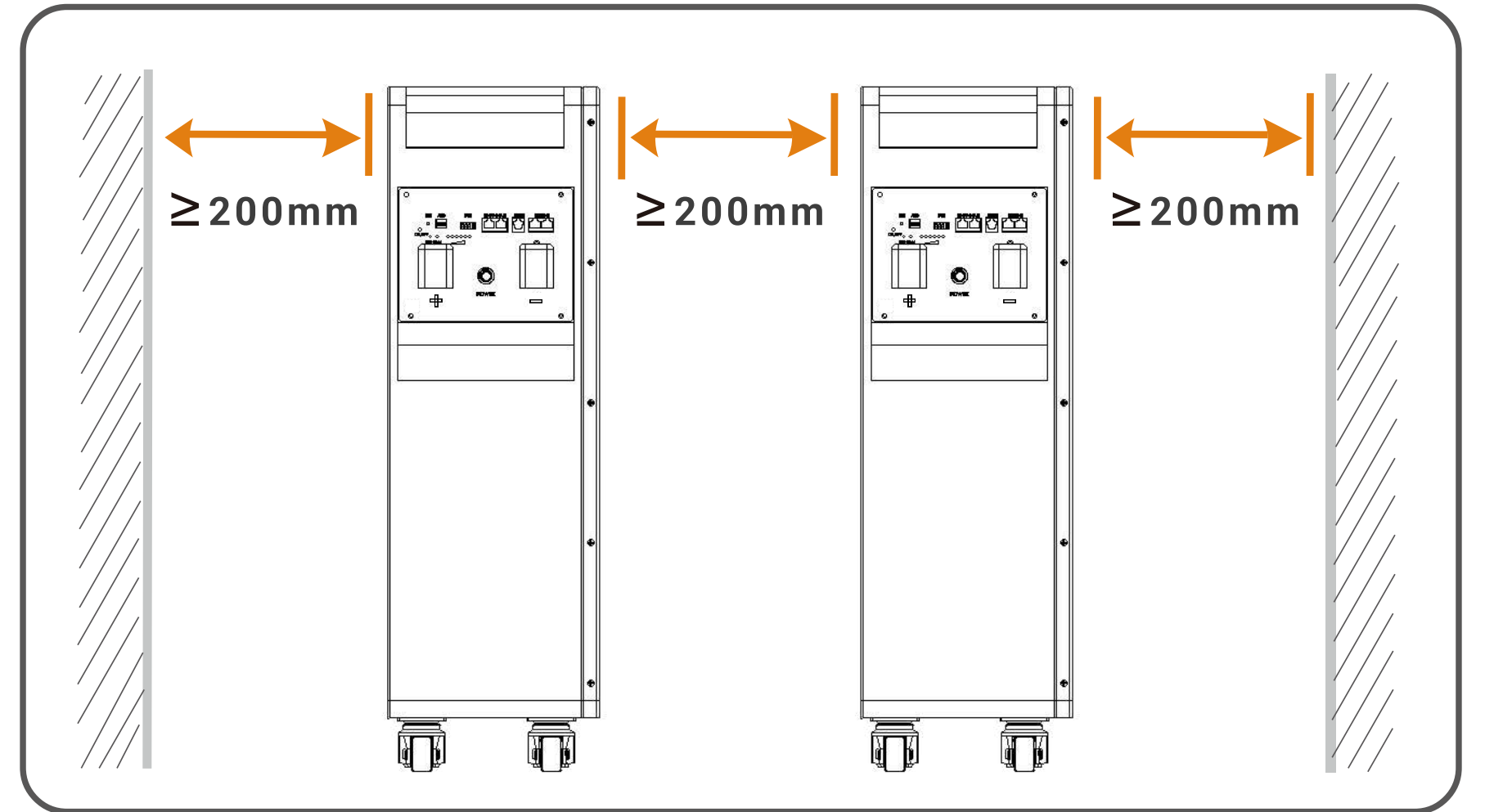
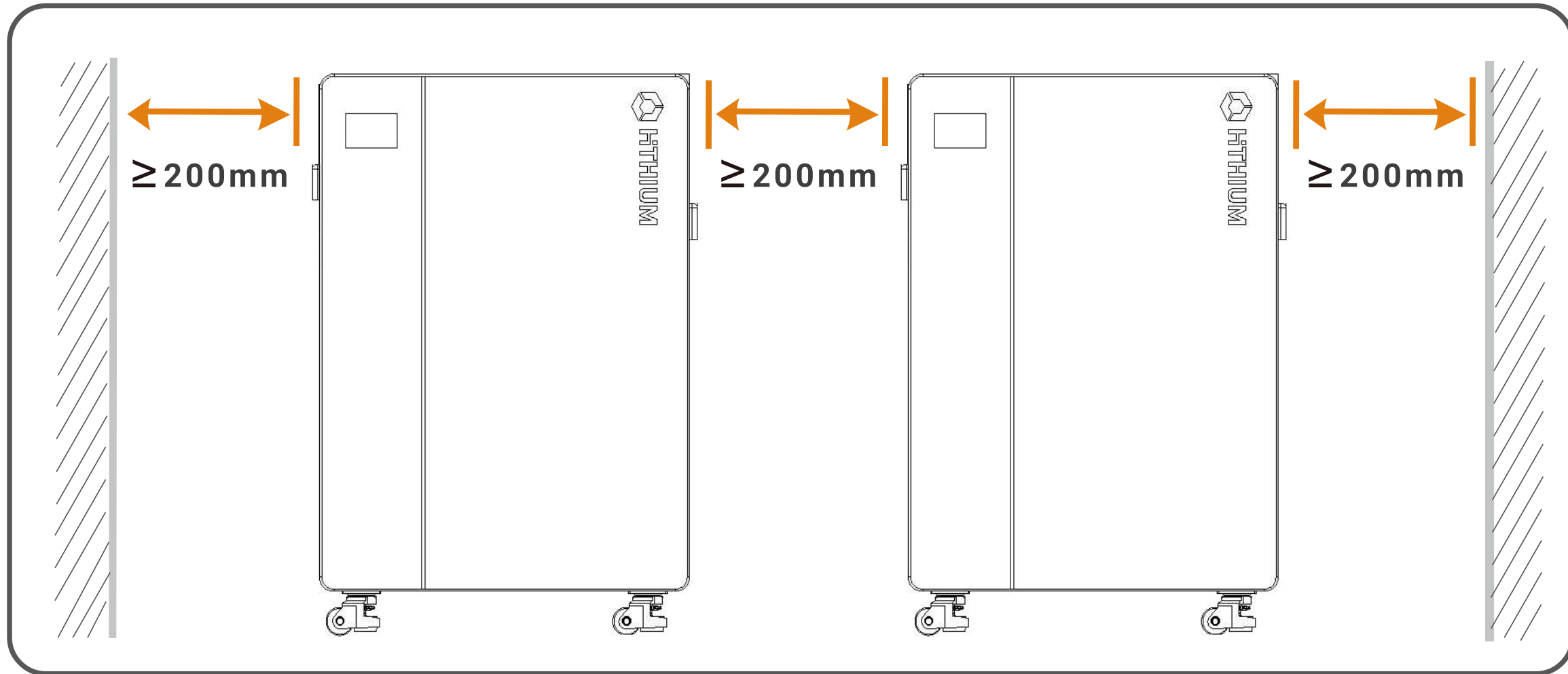
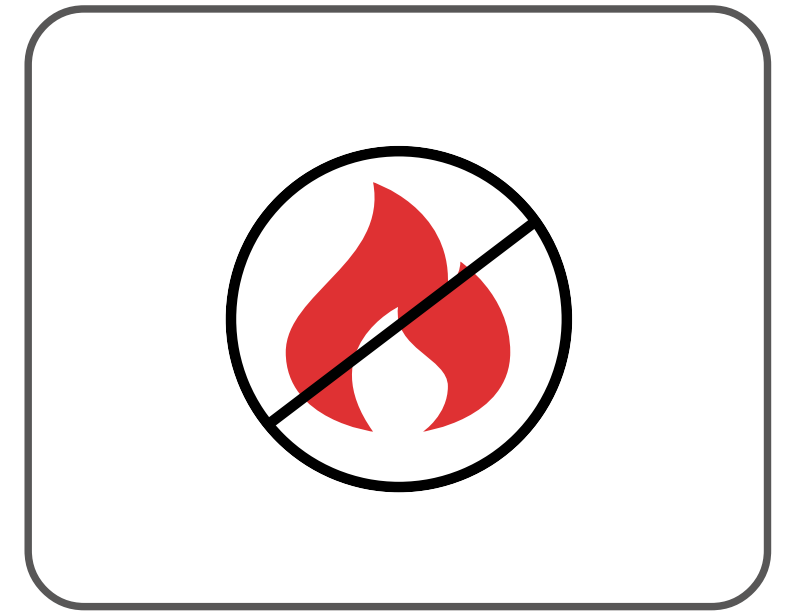
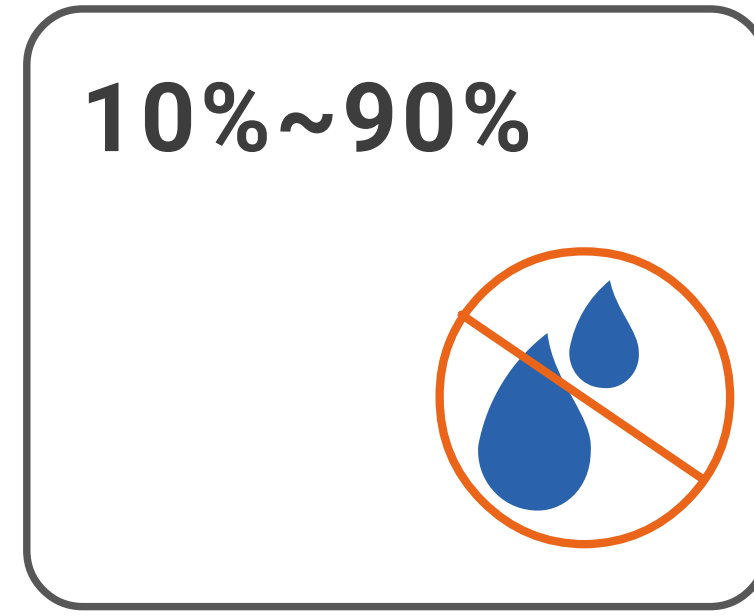
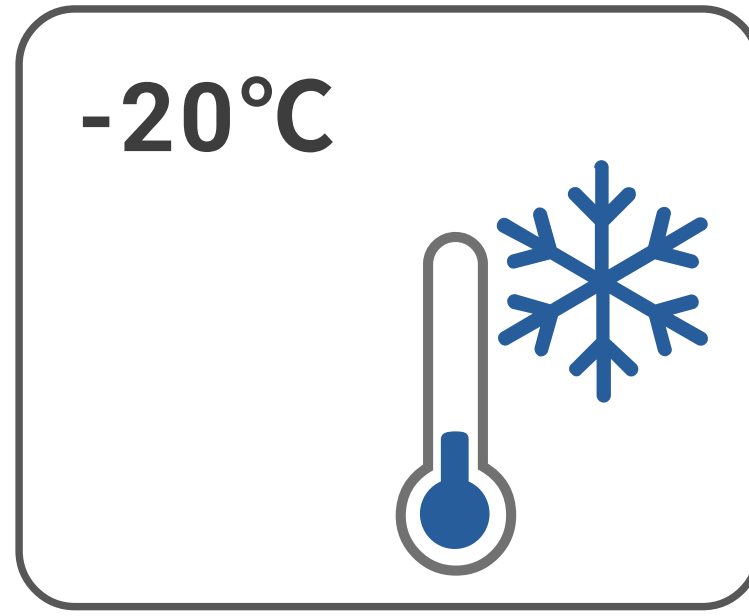
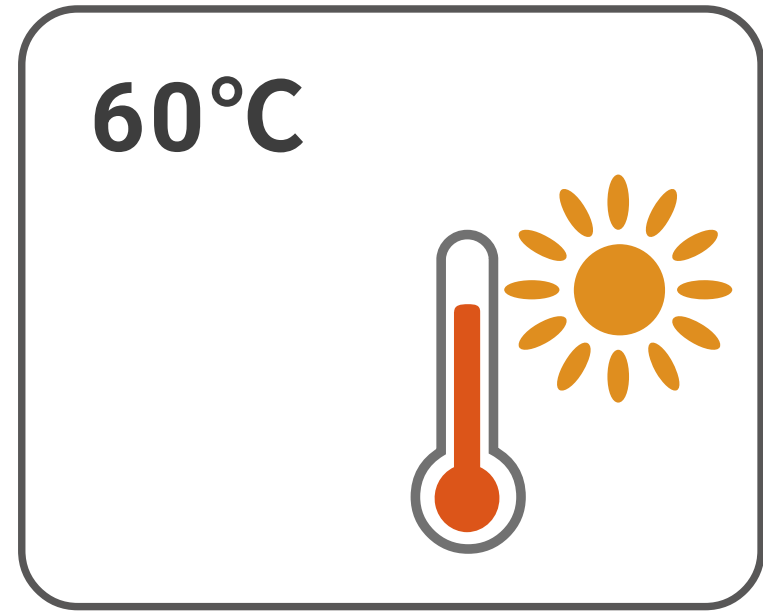

## 6.3 Wheel Securing

To ensure the stability and safety of the battery pack during use and movement, we specifically remind users to secure the wheels when installing and positioning the battery pack. Here are detailed instructions for securing the wheels:

1. Check Wheel Status: Before moving the battery pack, make sure all wheels are locked to prevent slipping or rolling during the move.
2. Perform Wheel Securing: Depending on the design of the battery pack, operate the locking mechanism to secure the wheels. For button-style locks, you may need to press and rotate the wheel; for lever-style locks, you may need to turn the lever to a vertical position and secure it.
3. Confirm Securing Effect: After securing the wheels, gently shake the battery pack to ensure the wheels do not move. If the wheels can still rotate, please recheck the locking mechanism and make adjustments.
4. Safety Warning: Unsecured wheels may cause the battery pack to be unstable during use or charging, increasing the risk of tipping or moving. Always ensure the wheels are secured to avoid potential safety incidents.
5. Moving Suggestions: If you need to move the secured battery pack, please use the recommended handling methods, such as lifting the battery pack or using appropriate handling tools.

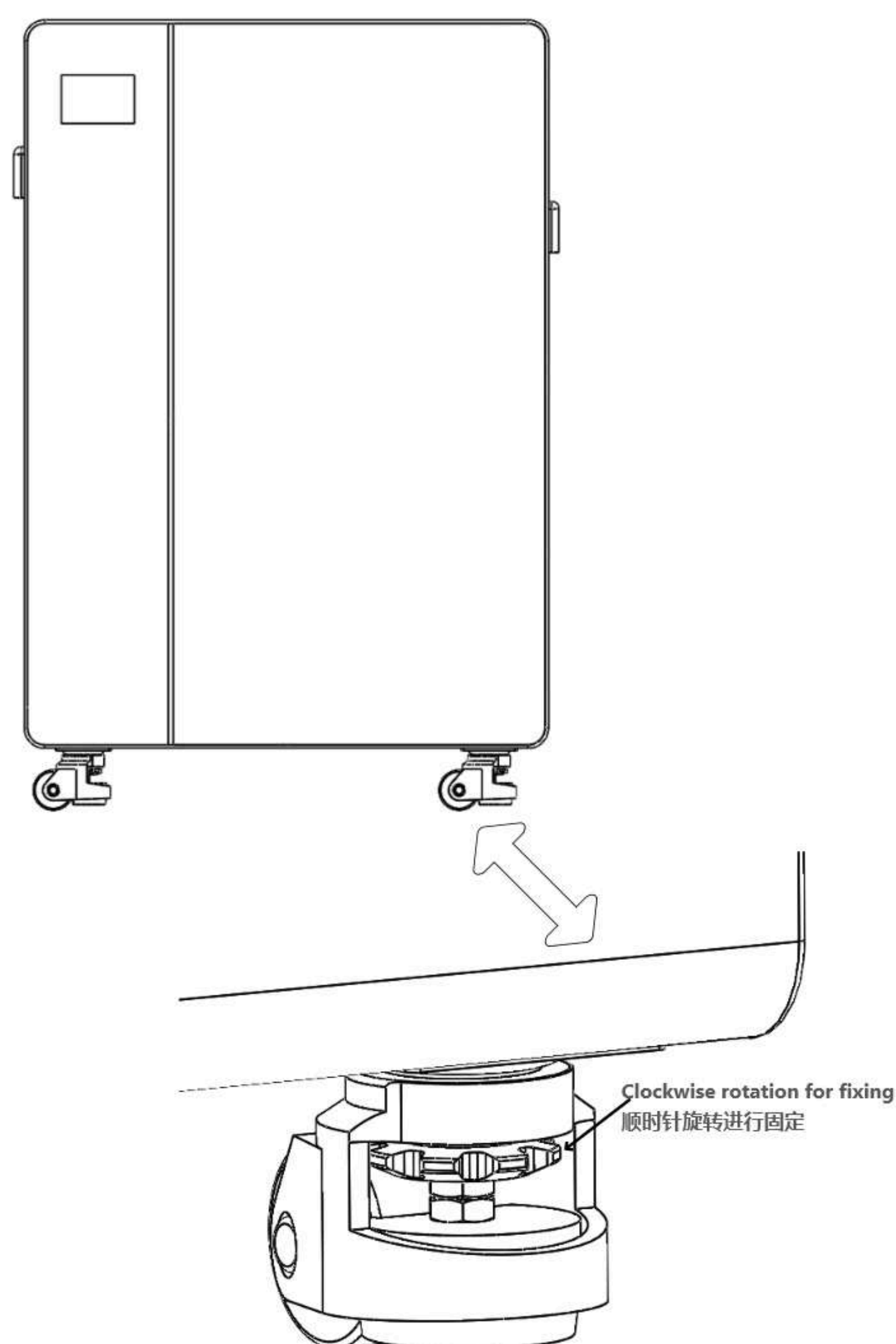

## 6.4 Battery connection

### ⚠ Warning!

- Before installing the battery, please carefully read and understand all warnings and precautions to avoid equipment failure or personal injury caused by improper operation!

### ⚠ Attention!

- Please use cable specifications reasonably and avoid using overly thin cables to prevent serious heating and potential fire hazards.

AWG	sectional area mm <sup>2</sup>	normal current A	maximum current A <sub>max</sub>
2/0	67.43	266	303
1/0	53.49	211	241
1	42.41	167	191
2	33.62	133	151
3	26.67	105	120
4	21.15	83	95

### 6.4.1 Single battery connection

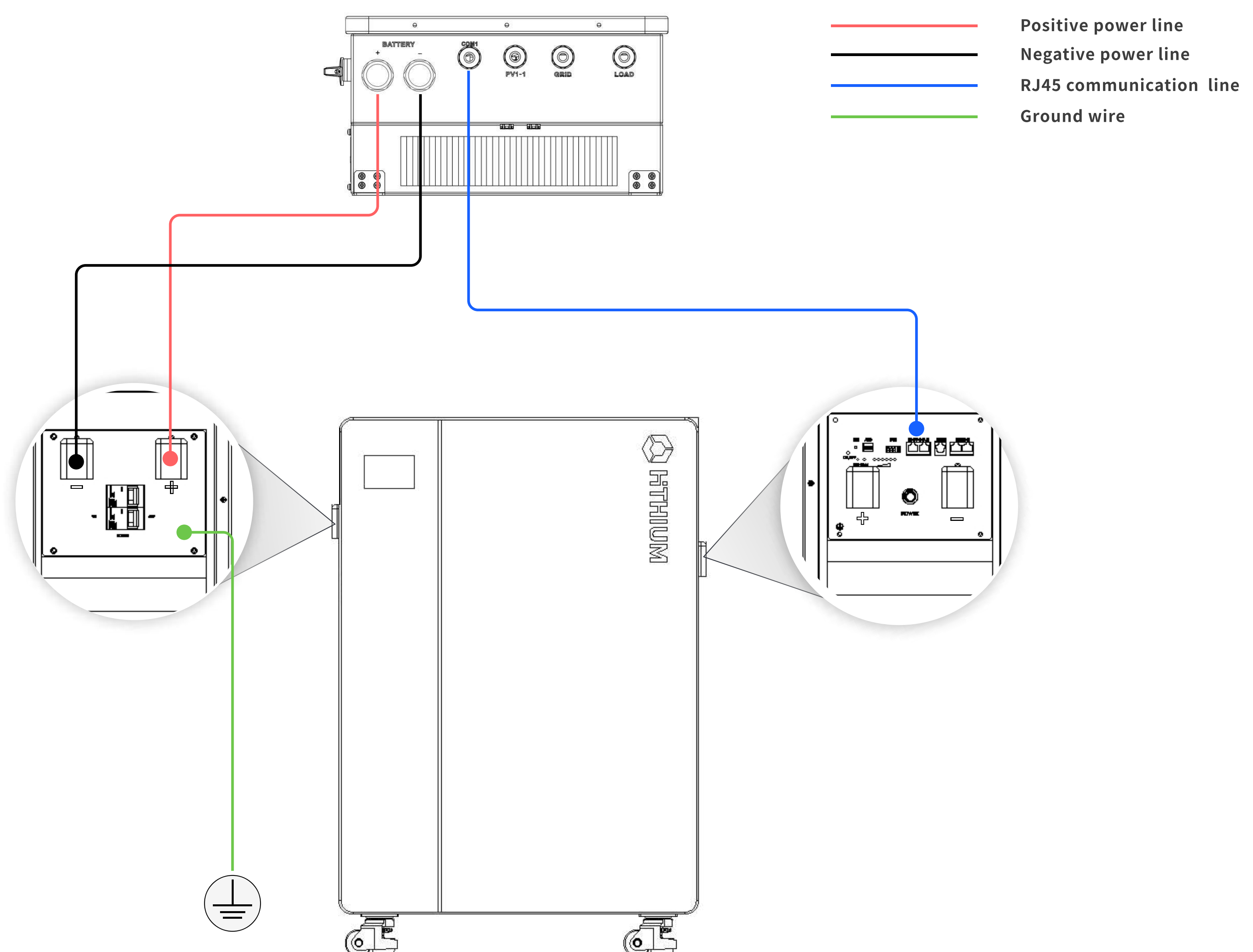

## 6.4.2 Multiple battery connections

### ⚠ Warning!

- Please ensure that the voltage difference between the newly replaced battery and other parallel battery packs is within 2V or the difference in state of charge (SOC) is within 20%. If the voltage difference is too large, the battery with a high voltage will charge the battery with a low voltage with a large current, and the battery pack with a low voltage will be subject to overcurrent protection during charging, resulting in inability to charge!

### ⚠ Attention!

- Please use cables of the same specification to connect the batteries, and use two copper bars to connect the positive and negative poles of the batteries respectively to ensure that the connection resistance between each battery cell is consistent and reduce battery imbalance caused by differences in connection resistance.

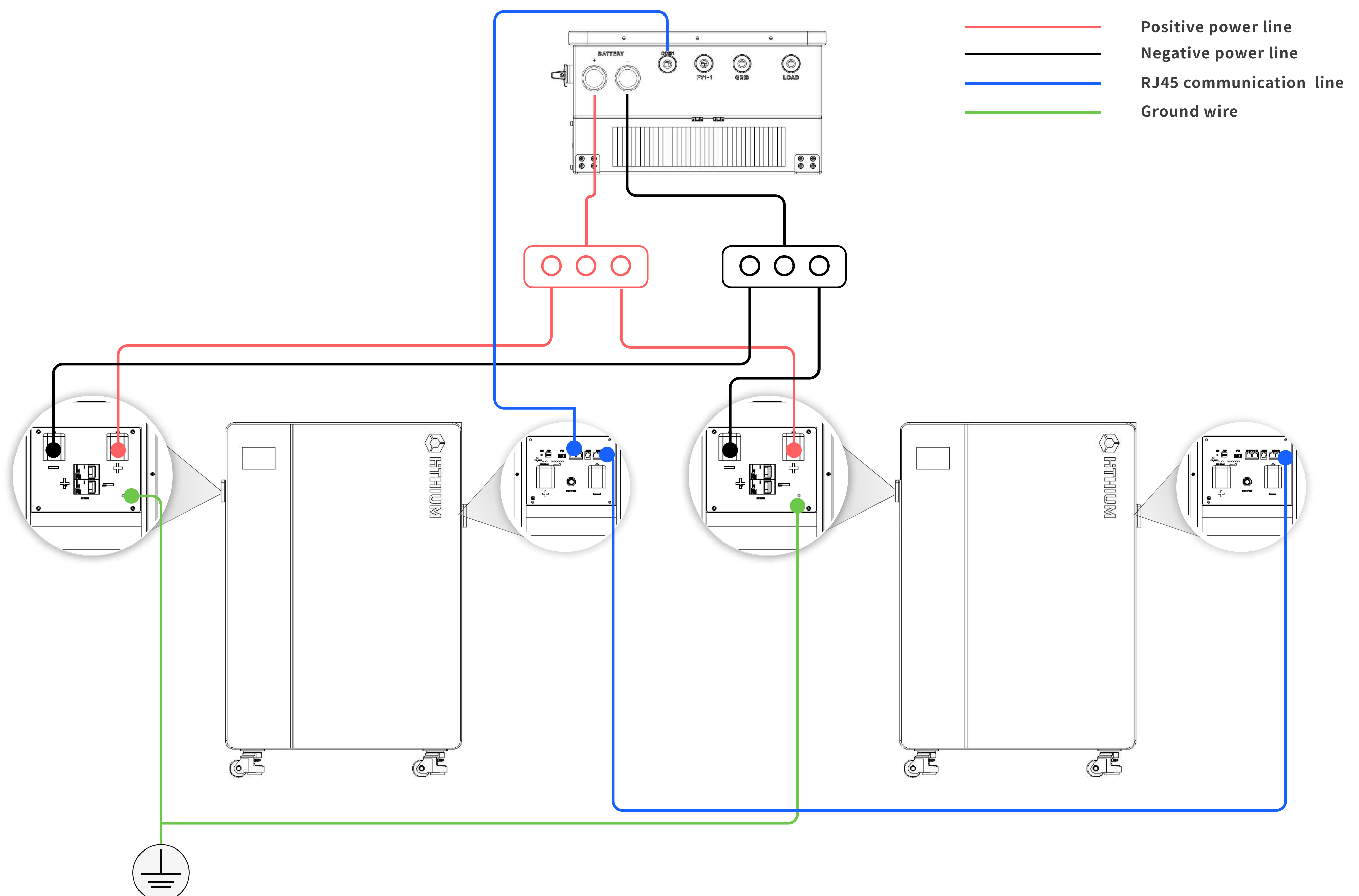

### 6.4.3 Multiple inverters connections

#### ⚠ Warning!

- When the system is running and the ALM indicator light on the battery is on and red for a long time, the battery circuit breaker should be disconnected in time, the battery fault information should be checked, and it should be handled with reference to <9. Common problem analysis and solutions>!

#### ⚠ Attention!

- Please configure a dedicated DC circuit breaker independently for each inverter. Close them one by one in sequence (the lower level can be operated only after the previous level is started). Illegal operations may trigger battery short-circuit protection and interrupt the system operation.
- Please install the DC circuit breaker according to the maximum current of the inverter.

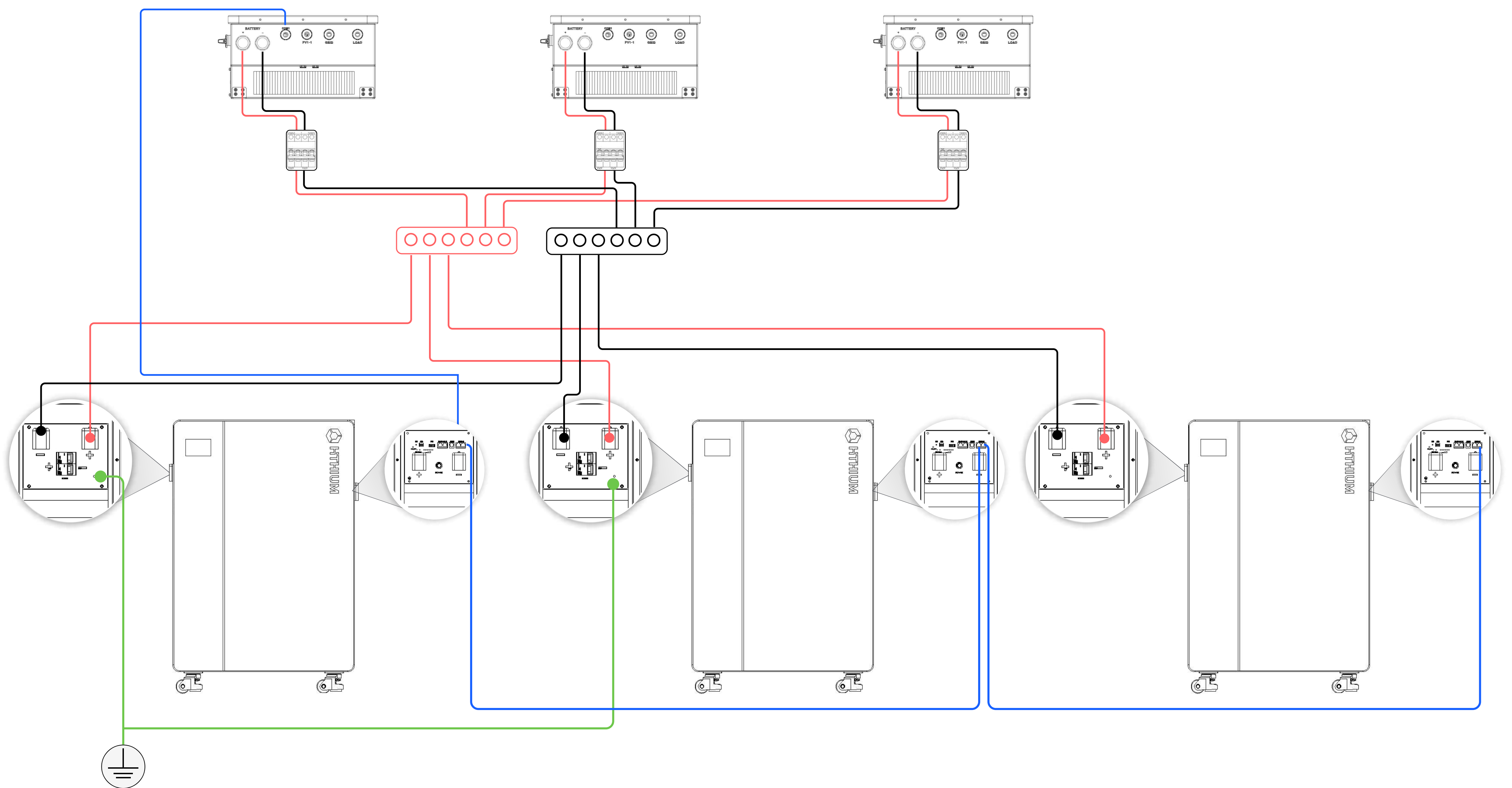

## 6.5 Communication connection

### 6.5.1 BMS communication

#### ⚠ Attention!

- Please carefully read the BMS communication manual of external devices (such as inverters, etc.) to ensure that the communication interface is consistent with the battery communication interface!

The left side is the RS485 communication interface, and the right side is the CAN communication interface, both of which are used for communication between the battery pack and external devices (such as inverters).

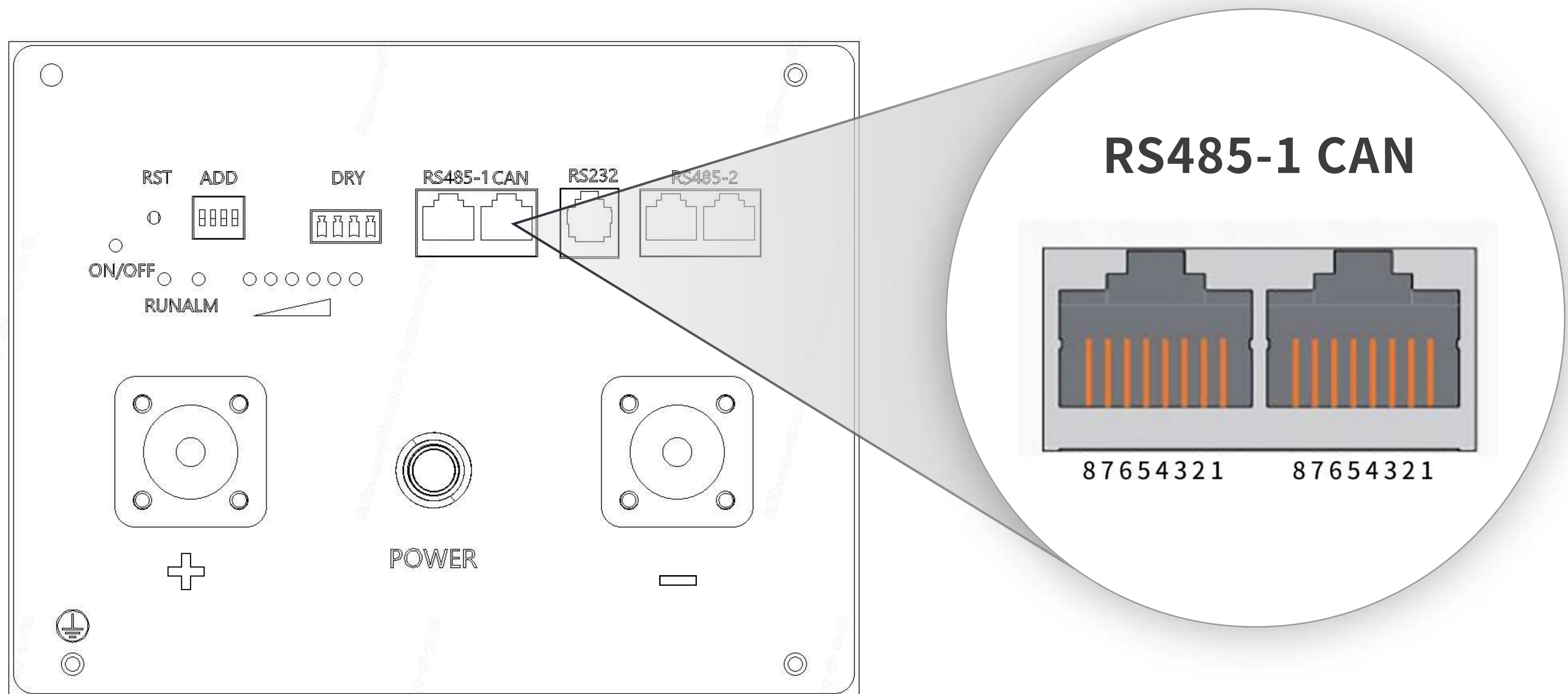

Interface	Definition		Definition			
BMS Communication port definition	RS485-1	PIN1	RS485-B1	CAN	PIN1	CANL
		PIN2	RS485-A1		PIN2	CGND
		PIN3	RS485-GND		PIN3	NC(Empty)
		PIN4	RS485-B1		PIN4	CANH
		PIN5	RS485-A1		PIN5	CANL
		PIN6	RS485-GND		PIN6	NC(Empty)
		PIN7	NC(Empty)		PIN7	CGND
		PIN8	NC(Empty)		PIN8	CANH

## 6.5.2 Battery-to-battery communication

### ⚠ Attention!

- Please set the battery DIP address for communication with the inverter to 1 and call it the main battery. Set other batteries in the order of 2 to 15 and call them slave batteries.
- Only the communication line of the main battery needs to be connected to the inverter. Other slave batteries do not need to be connected to the inverter.
- For the communication connection between batteries, please follow the left-in-right-out connection method, that is, connect from the right port of RS485-2 of the main battery to the left port of RS485-2 of the slave battery as shown in the connection.

Used to achieve communication interconnection when battery packs are connected in parallel.

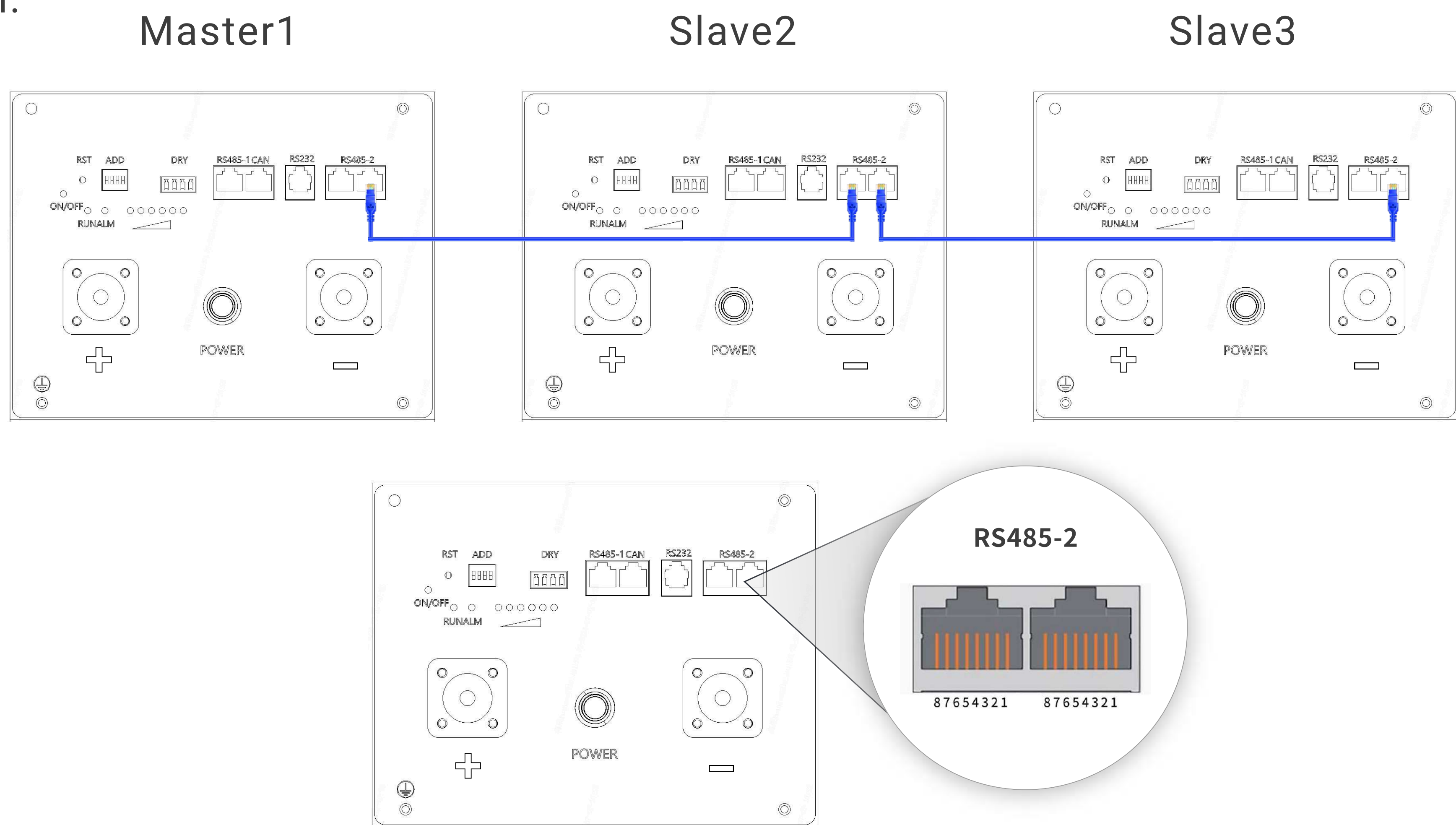

Interface	Definition		
Battery Cascade Communication Port	RS485-2	PIN1	RS485-B2
		PIN2	RS485-A2
		PIN3	RS485-GND
		PIN4	NC(Empty)
		PIN5	NC(Empty)
		PIN6	RS485-GND
		PIN7	RS485-A2
		PIN8	RS485-B2

### 6.5.3 DIP switch setting

#### ⚠ Attention!

- When a single battery is connected, set the position of the DIP switch to 1;
- When multiple batteries are connected in parallel, set the main battery communicating with the inverter to 1, and set other addresses in the order of 2 to 15.

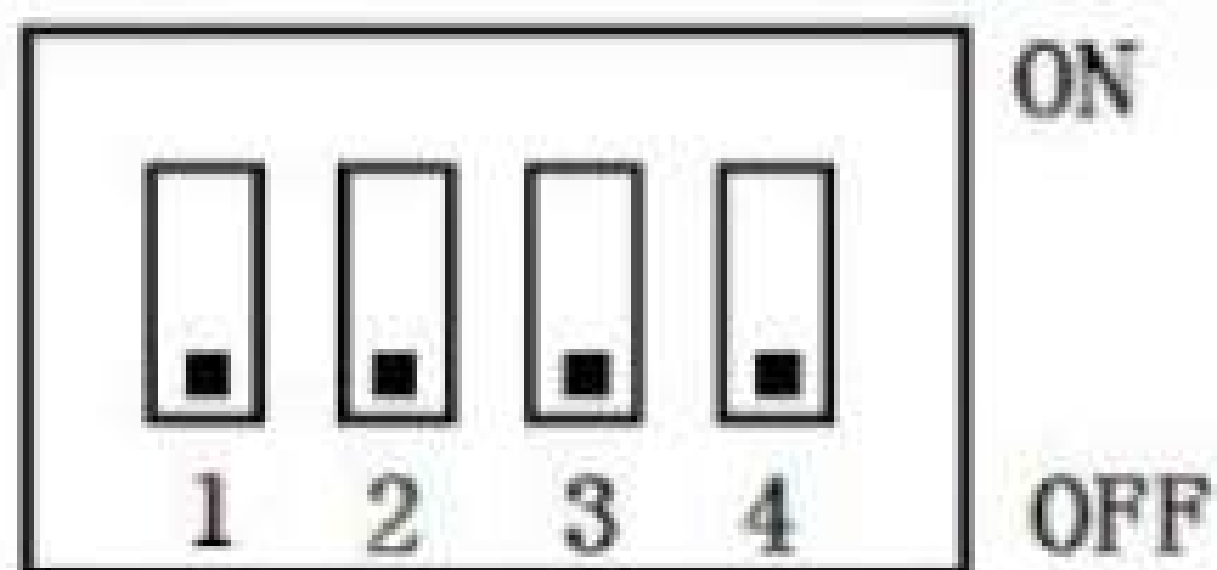

Address	Dial switch position			
	#1	#2	#3	#4
1	ON	OFF	OFF	OFF
2	OFF	ON	OFF	OFF
3	ON	ON	OFF	OFF
4	OFF	OFF	ON	OFF
5	ON	OFF	ON	OFF
6	OFF	ON	ON	OFF
7	ON	ON	ON	OFF
8	OFF	OFF	OFF	ON
9	ON	OFF	OFF	ON
10	OFF	ON	OFF	ON
11	ON	ON	OFF	ON
12	OFF	OFF	ON	ON
13	ON	OFF	ON	ON
14	OFF	ON	ON	ON
15	ON	ON	ON	ON

## 6.6 Ground wire connection

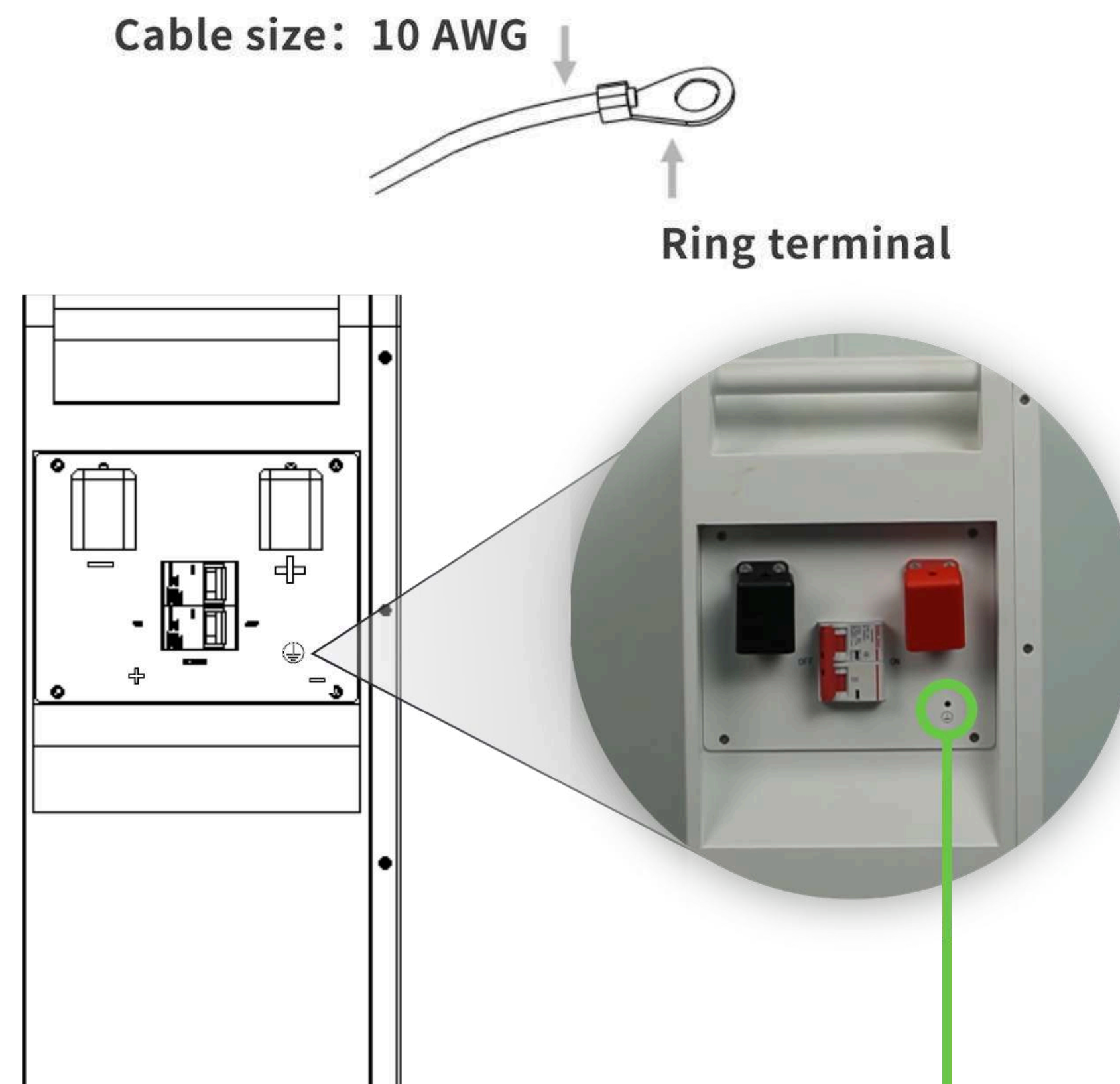

## 7. System startup and shutdown

### 7.1 Check before power on

#### ⚠ Attention!

- When powering on the battery system, please be sure to check the following items to prevent system damage.
- The inverter is firmly installed. The installation location is convenient for operation and maintenance. The installation space is convenient for ventilation and heat dissipation. The installation environment is clean and tidy.
- All DC circuit breakers are in the off state.
- The ground wire, load wire, and communication wire are all connected correctly and firmly.
- The cable bundling meets the wiring requirements, is reasonably distributed, and there is no damage.
- Unused ports have been blocked.

### 7.2 Battery system start-up

- Press the "power" button to start the battery system. When multiple batteries are connected, start the main battery first and then the slave battery.
- Wait for the battery system to start. During this period, the indicator lights will flash alternately.

- Wait for the indicator lights to stabilize and the screen to display normally. The startup is complete.

### 7.3 Close the circuit breaker to enable output

#### ⚠ Attention!

- Be sure to close the circuit breaker according to the following steps to ensure that no battery failure occurs.

#### 7.3.1 Single battery connection

#### ⚠ Warning!

- When the system is powered on, if the ALM indicator light on the battery is constantly on red, the battery circuit breaker should be disconnected in time and refer to <9. Common problem analysis and solutions> for handling!

1. Close the battery circuit breaker and wait for the battery indicator light to be normal.

#### 7.3.2 Multiple battery connections

#### ⚠ Attention!

- Before closing the main battery, please click on each battery display screen to view the battery voltage and SOC. Confirm that the battery voltage difference is within 2V or the SOC difference is within 20%. If not within the range, please perform equalization treatment on the battery first and then connect it to the battery pack. For example, discharge the battery with a higher SOC or charge the battery with a lower SOC until the voltage or SOC of the two is close, and then connect them in parallel.

1. Please close the main battery circuit breaker first. Wait until the main battery indicator light is normal. Then close the slave battery circuit breaker until all battery indicator lights are normal.
2. Click the parallel connection button on the main battery screen and perform page-turning operations. Check whether the slave battery data of the corresponding DIP switch address is consistent with the monitoring data. If not, please check the DIP switch settings.

### 7.3.3 Multiple inverters connections

#### **⚠ Warning!**

- When operating the power-on steps, a DC circuit breaker must be installed. It is prohibited to power on multiple inverters simultaneously; otherwise, it will cause a battery short circuit and damage to the equipment
- In case of short-circuit protection, please check the cable line to ensure there are no wiring problems. Wait for the battery to automatically perform maintenance without shutting down and restarting. If the fault still exists after a long wait, please follow <7.6 System Shutdown> for processing and contact customer service in time!

1. Please refer to <7.3.2 Multiple battery connections>;
2. Wait for 10 seconds and check the status of all battery indicator lights to ensure there are no alarms or faults;
3. Close the DC circuit breakers of the inverters one by one in sequence. Ensure that the previous-stage inverter is working properly before operating the next-stage inverter. Illegal operations will trigger battery short-circuit protection and interrupt the system operation!

### 7.4 Indicator light status

Table 1 LED status indication









Mode	Normal/Alarm/Protection	ON/OFF 	RUN 	ALM 	LED Battery indicator LED						Instruction	
					L6 	L5 	L4 	L3 	L2 	L1 		
Power off	Sleep	OFF	OFF	OFF	OFF	OFF	OFF	OFF	OFF	OFF	Lights completely off	
Stand by	Normal	ON	Flash 1	OFF	Based on Battery Level indication						Standby Mode	
	Alarm	ON	Flash 1	Flash 3	Based on Battery Level indication						Module Under-voltage	
Charge	Normal	ON	ON	OFF	Based on Battery Level indication The highest battery level LED flashes (flash 2)						The highest battery level LED flashes (flash 2) Overcharge alarm active, ALM LED steady	
	Alarm	ON	ON	Flash 3	Based on Battery Level indication The highest battery level LED flashes (flash 2)						The highest battery level LED flashes (flash 2) Overcharge alarm active, ALM LED steady	
	Overcharge protection	ON	ON	OFF	ON	ON	ON	ON	ON	ON	If there is no mains power, the indicator light switches to standby mode	
	Temperature/Overcurrent/Failure Protection	ON	OFF	ON	OFF	OFF	OFF	OFF	OFF	OFF	OFF	Stop charging
Dis-charge	Normal	ON	Flash 3	OFF	Based on Battery Level indication							
	Alarm	ON	Flash 3	Flash 3	Based on Battery Level indication							
	Undervoltage protection	ON	OFF	OFF	OFF	OFF	OFF	OFF	OFF	OFF	OFF	Stop discharging
	Temperature/overcurrent/short circuit/reverse connection/failure protection	ON	OFF	ON	OFF	OFF	OFF	OFF	OFF	OFF	OFF	Stop discharging
Failure		OFF	OFF	ON	OFF	OFF	OFF	OFF	OFF	OFF	OFF	Stop charging/Discharging

Table 2 Description of capacity indication

Mode		Charge						Discharge					
Capacity Indicator Light		L6	L5	L4	L3	L2	L1	L6	L5	L4	L3	L2	L1
SOC (%)	0%~17%	Flash 2	OFF	OFF	OFF	OFF	OFF	ON	OFF	OFF	OFF	OFF	OFF
	18%~33%	ON	Flash 2	OFF	OFF	OFF	OFF	ON	ON	OFF	OFF	OFF	OFF
	34%~50%	ON	ON	Flash 2	OFF	OFF	OFF	ON	ON	ON	OFF	OFF	OFF
	51%~66%	ON	ON	ON	Flash 2	OFF	OFF	ON	ON	ON	ON	OFF	OFF
	67%~83%	ON	ON	ON	ON	Flash 2	OFF	ON	ON	ON	ON	ON	OFF
	84%~100%	ON	ON	ON	ON	ON	Flash 2	ON	ON	ON	ON	ON	ON
Operation Indicator Light ●		ON						Flashing(Flash 3)					

Table 3 LED flashing description

Flashing Mode	ON	OFF
Flash 1	0.25S	3.75S
Flash 2	0.5S	0.5S
Flash 3	0.5S	1.5S

Note: The LED indicator light alarm can be enabled or disabled via the host computer. It is enabled by default at the factory.

## 7.6 System Shutdown

1. Turn off the inverter;
2. Turn off the DC circuit breaker of the inverter;
3. Disconnect the battery circuit breaker;
4. Press the “power” button.

## 7.7 Inverter settings

### ⚠ Attention!

- When connecting using an inverter, please set the battery parameters reasonably to avoid damaging the battery.
  - Please set the depth of discharge to not exceed 90%. After discharging, the battery can retain more than 10% of its power to avoid over-discharging of the battery.
  - Do not use a current close to or greater than 200A to charge or discharge the battery for a long time (more than 1 hour) to avoid over-temperature or over-current protection of the battery, which may affect the service life of the battery.
- When the battery current exceeds 200A, the current will be automatically limited to 20A. When it exceeds 210A, overcurrent protection will be triggered.

- When there is abnormal communication between the battery and the inverter, you can set the battery type as lead-acid or adjust the mode to voltage mode on the inverter, and refer to the following table for battery voltage setting. For more help, please contact customer service.

1. Please read the inverter operation manual carefully and make corresponding settings to better use the battery. The following is a reference for battery parameter settings:

No	Settings item	Unit	Value
1	battery capacity	Ah	314
2	Battery type	--	LiFePO4
3	Full charge voltage	V	57.6
4	Floating charge voltage	V	56
5	Discharge cut-off voltage	V	49.6
6	Discharge cut-off capacity	%	10
7	Maximum charging/discharging current	A	Refer to the following table.

## **⚠ Warning!**

- It is prohibited to set the maximum current of the inverter to the total maximum current of the battery. Due to the different internal resistances of cables and batteries, it is easy for an imbalance in current distribution to occur, leading to excessive current in a single battery. Please refer to the following table for settings. If overcurrent protection still occurs, the maximum current should be set lower appropriately.

Number of parallel-connected batteries	derating coefficient	Maximum charging/discharging current (A)
1	1	200
2	0.85	340
3	0.75	450
4	0.65	520
5	0.6	600
6	0.5	600

## 7.8 Battery and inverter communication check

### **⚠ Attention!**

- Please check whether the information on the battery display is consistent with that displayed by the inverter to ensure normal communication.

1. Please check whether the following information is consistent.

No	Check content
1	BMS communication protocol
2	Battery voltage
3	Battery power SOC

## 8. Screen introduction

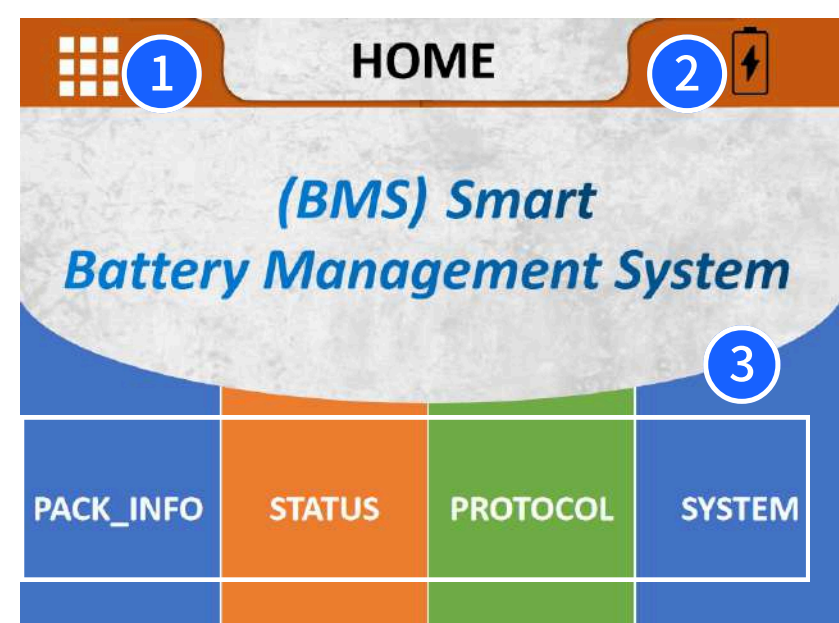

Instructions:

1. Main interface button
2. Parallel interface button
3. Menu bar



Instructions:

1. RS485 communication port protocol



Instructions:

1. Battery Information
  - a. PACK\_V: Battery voltage
  - b. PACK\_V: Charge/discharge current
  - c. SOC: State of Charge
  - d. RM\_CAP: Remaining capacity
  - e. FULL\_CAP: Full charge capacity

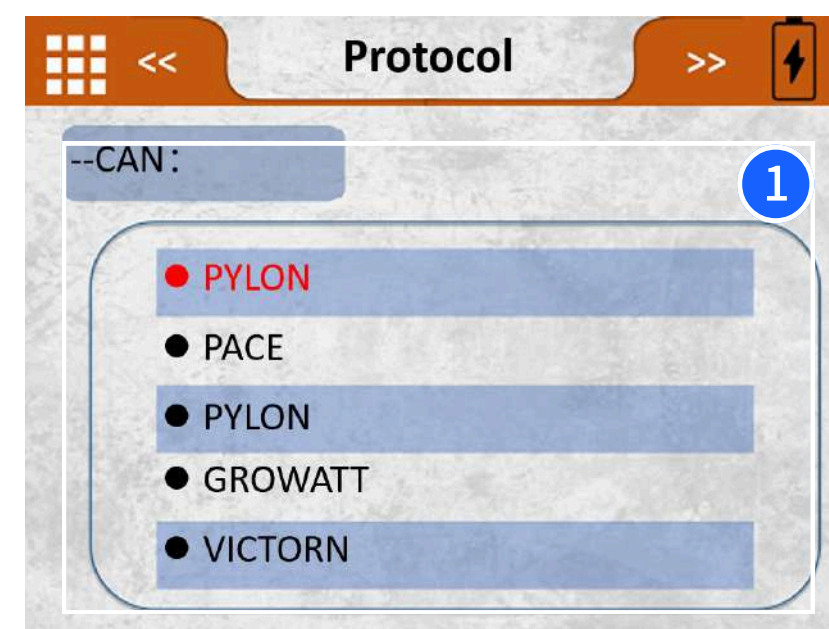

Instructions:

1. CAN communication port protocol

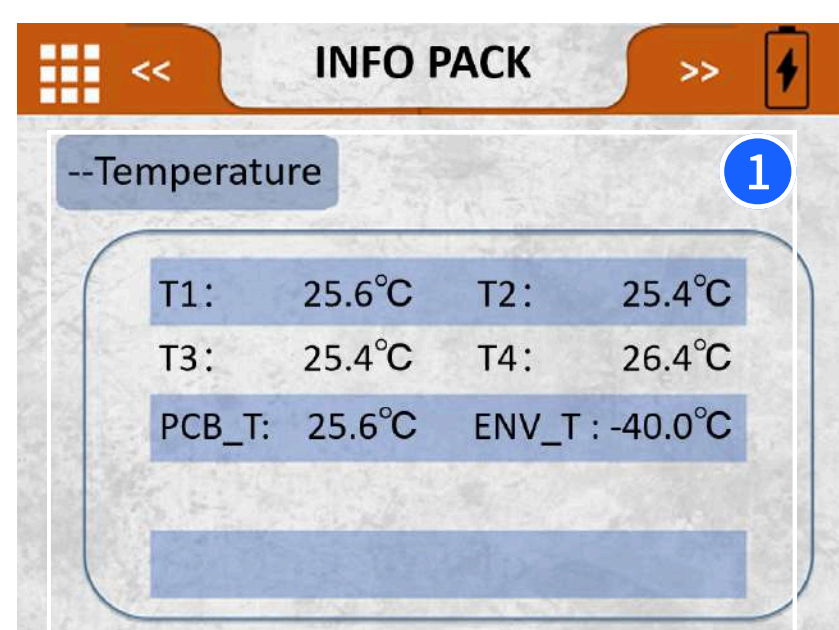

Instructions:

1. Battery temperature:
  - Cell temperature,
  - BMS temperature,
  - Internal ambient temperature.



Instructions:

1. System Info:
  - Battery SN
  - System Version
  - System Language (click to change)

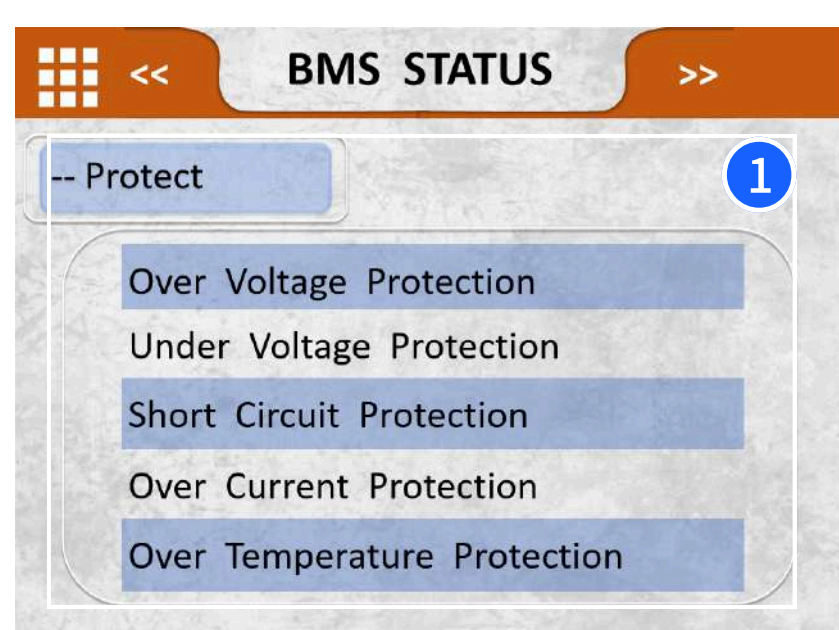

Instructions:

1. Fault-triggered info: On fault, text turns red; ALM indicator stays red.

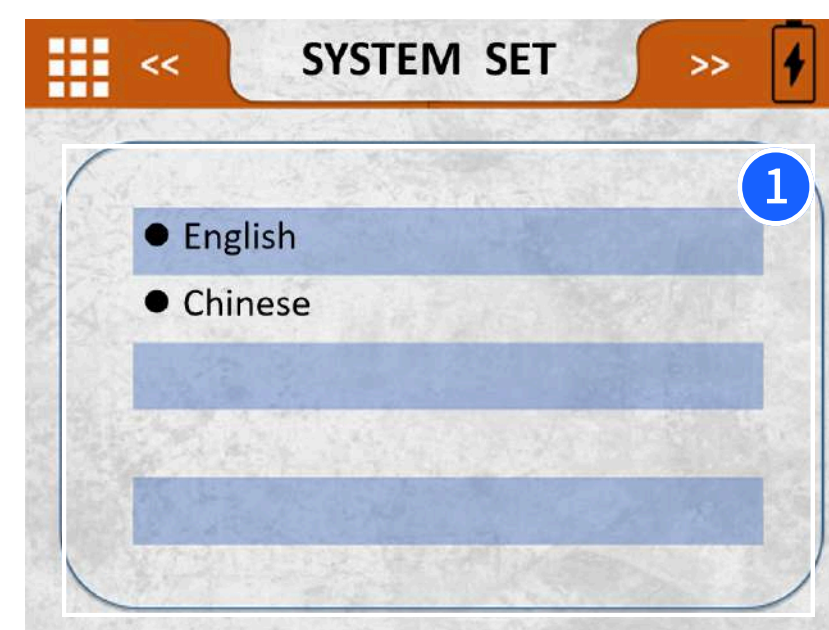

Instructions:

1. Switch between Chinese and English

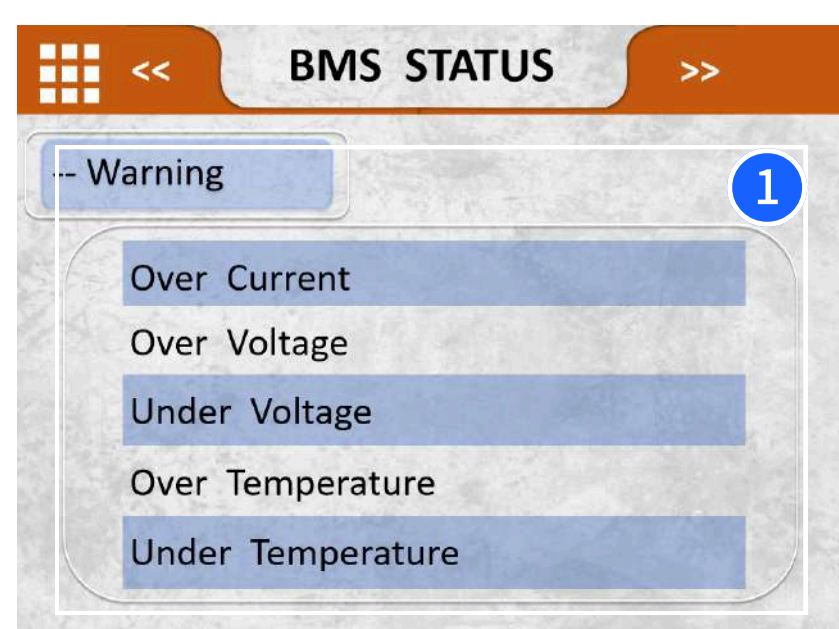

Instructions:

1. Alarm info: On alarm, text turns red; ALM indicator flashes red.

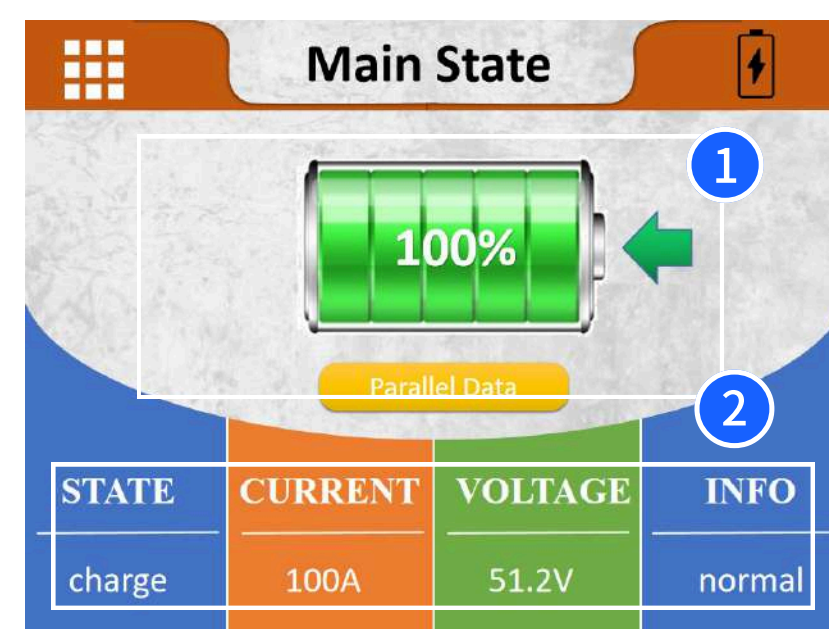

Instructions:

1. Average SOC of the parallel system
2. Status of the parallel system, which from left to right is voltage status, total current, average voltage, and operating status.

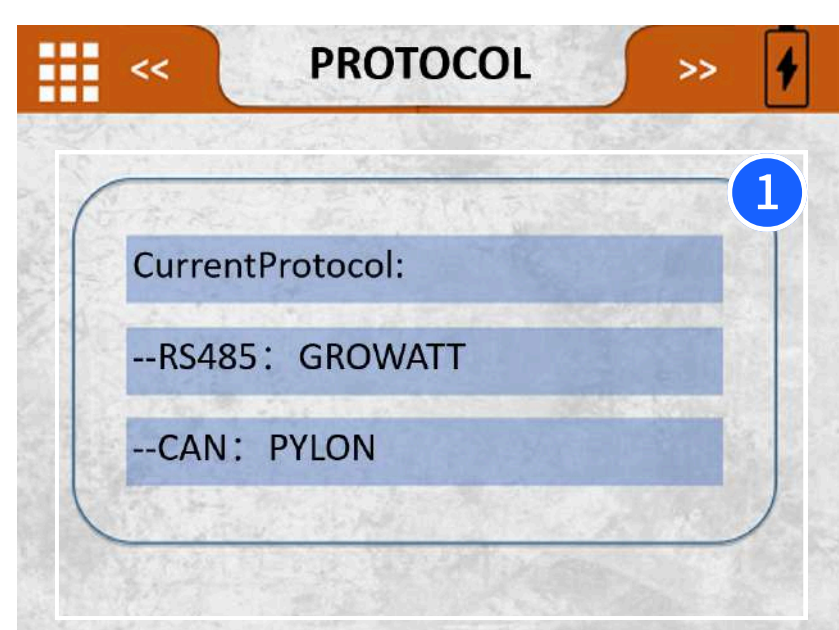

Instructions:

1. Currently used communication protocol.
2. Do not modify the communication protocol without authorization. If changes are required, please contact the installer.

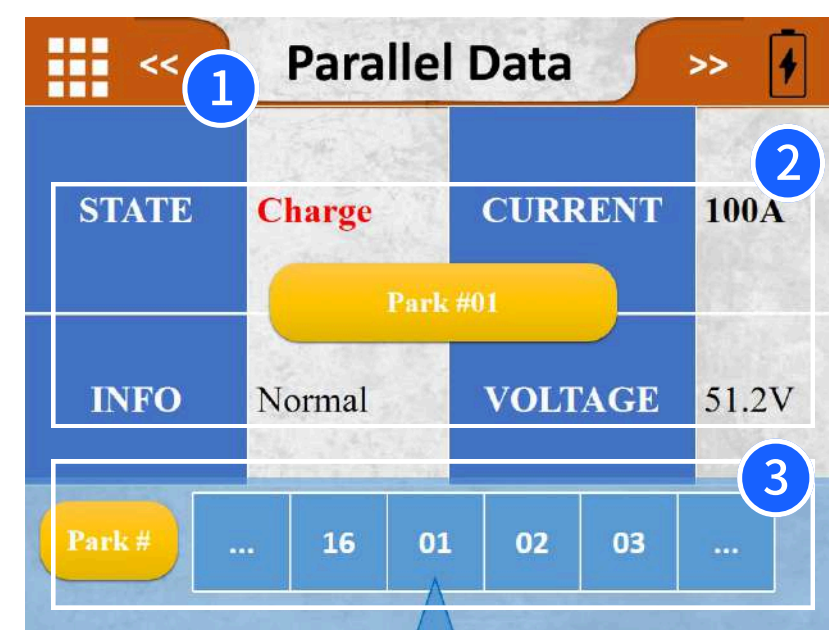

Instructions:

1. Page-turning buttons
2. Parallel monitoring: shows battery info at corresponding addresses, including charge/discharge status, charge current, operating status, and total voltage.
3. Parallel address: choose the battery with the corresponding DIP switch address.

## 9.Common problem analysis and solutions

problem	ALM indicator light status	reason	Solution
Alarm - Overcurrent	Flash	Remind that the battery charging or discharging current is close to the protection value.	Please check the maximum current setting of the inverter to ensure that the current is lower than the maximum current of the battery.
Alarm - Overvoltage	Off	Remind that the battery is close to full charge.	Please avoid long-term charging.
Alarm - Low voltage	Off	Remind that the battery is close to empty.	Please charge in time.
Alarm - Over temperature	Flash	Remind that the battery temperature is too high.	<ul style="list-style-type: none"> <li>• Please stop battery charging or discharging in time.</li> <li>• Please place the battery within the operating temperature range.</li> </ul>
Protection - Overvoltage	on	The battery voltage has exceeded the protection value.	<ul style="list-style-type: none"> <li>• Please stop charging the battery immediately and release electrical energy appropriately. After the battery protection is lifted, charging can continue.</li> </ul>
Protection - Low voltage	on	The battery voltage has dropped below the protection value.	<ul style="list-style-type: none"> <li>• Please charge the battery immediately and charge it to more than 20% of its capacity. After the battery protection is lifted, discharging can continue.</li> </ul>
Short circuit protection	on	There is a short circuit in the line connection or the total installed power of the inverter is too large.	<ul style="list-style-type: none"> <li>• Please close the battery circuit breaker in time.</li> <li>• Please check whether the line connection is normal and confirm that there is no short circuit in the line.</li> <li>• If it occurs when connected to the inverter, it means that there are electrical components with large current inside the inverter. Generally, it often occurs in inverters with a single unit power exceeding 10kW or when multiple inverters are connected. Please replace with an inverter with a smaller power or reduce the number of inverter connections and reinstall it according to the manual. If you continue to use it, there will be a risk of damaging the battery protection board!</li> <li>• If it occurs after installation: <ul style="list-style-type: none"> <li>• Please turn off the inverter immediately and disconnect the battery circuit breaker.</li> <li>• Please check whether the cable is damaged and whether there is a short circuit in the line.</li> <li>• After confirming that there is no problem with the line, please wait for the battery to recover on its own. If it does not recover for a long time (more than 20 minutes), the battery protection board may be damaged. Please contact after-sales service in time.</li> <li>• If the battery indicator light has returned to normal, please refer to &lt;7. System startup and shutdown&gt; to try to restart the system and check the inverter settings to ensure that the settings meet the battery requirements.</li> </ul> </li> </ul>
Protection - Overcurrent	on	The battery charging or discharging current has exceeded the protection value.	<ul style="list-style-type: none"> <li>• Please stop charging or discharging immediately and adjust the maximum current of the inverter to a reasonable range. Wait for the battery to recover.</li> </ul>
Protection - Over temperature	on	The battery temperature has exceeded the protection value.	<ul style="list-style-type: none"> <li>• Please stop charging or discharging immediately and place the battery within the operating temperature range and wait for the battery temperature to return to normal.</li> </ul>
Screen and indicator lights are unresponsive	off	The battery has been completely discharged and the screen and indicator lights cannot work.	<ul style="list-style-type: none"> <li>• If the battery has been completely discharged, use an inverter or charger to activate the battery and charge it. Charge the battery to more than 70% of its capacity.</li> <li>• If the battery still cannot be activated, please contact customer service.</li> </ul>

Circuit breaker suddenly trips.	---	Excessive current or excessive operating temperature	<ul style="list-style-type: none"> <li>• Please immediately stop charging or discharging. Check the wiring and inverter settings to ensure that the operating current and operating temperature are within the required range.</li> <li>• If the circuit breaker still cannot be closed after multiple attempts, it may be damaged. Please contact customer service.</li> </ul>
Latest version update	---	Function optimization	<p>We will optimize and upgrade BMS functions irregularly. If you encounter a situation where old and new products are used together during use, please check the product version number via the screen.</p> <p><b>Please set the product with the latest version as the master device!</b></p> <p><b>Latest version: 50539-V1.10</b></p> <p>Historical versions (from new to old):</p> <ul style="list-style-type: none"> <li>• 50003V1.01B</li> <li>• CTP35H-31833-1.21</li> </ul>

## Warranty card

### User Info

Name:	Tel:
Email:	Zip Code:
Address:	

### Product Info

Mode:	Series No:
Purchase date:	Problem Description:

### Seller information

Company name:	Tel:
---------------	------



# HITHIUM



**After-Sales Service**  
**[aftersales@hithium.com](mailto:aftersales@hithium.com)**

**Shenzhen Hithium Hero Energy Equity Technology Co., Ltd**

601Room,Building 2,San Yi Yun Du Industrial Park, Longhua New District, Shenzhen City, Guangdong Province

**<https://www.hero-ee.com>**

The company reserves the right to modify the parameters and other information, specifications are subject to change without notice.